

## FIBRINOGEN SYNTHESIS, DISTRIBUTION AND DEGRADATION

E. B. Reeve, M.D., and J. J. Franks, M.D.

Fibrinogen is a plasma protein of approximately 340,000 daltons containing several per cent carbohydrate [169]. It is at least chiefly synthesized in the liver [156]. On exposure to thrombin it loses peptides [169] and forms long thin solid fibers [82]. These under the influence of fibrinase, Factor XIII [126, 133], become markedly insoluble in the blood and tissue fluids, unless attacked by proteolytic enzymes such as plasmin [225]. Collections of intertwined fibers block holes in vessels thereby inhibiting blood loss, sometimes block the lumen of vessels thereby causing thrombosis, sometimes circulate in the blood stream till they lodge in vessels to cause emboli [72] and probably form a matrix for cell growth as in wound healing [7, 278] and neoplastic spread [4]. A number of the many recent reviews of various aspects of fibrinogen behavior are noted below. Particularly relevant to what follows are reviews of the molecular structure of fibrinogen [169], the effects of proteolytic enzymes on fibrinogen [137], the pathways of catabolism of fibrinogen [167], the polymerization of fibrin monomers [63], the plasma and tissue fibrinogenolytic and fibrinolytic enzyme systems [152] and the control of protein synthesis in metazoan cells [168, 271, 232]. This review attempts to describe the physiology and pathophysiology of fibrinogen as it is synthesized, distributed to the blood stream and tissue fluids and catabolized, and to relate its somewhat extraordinary behavior to a few relevant features of what is known about other proteins. This requires discussion of some recent methods for studying fibrinogen metabolism and presentation of a picture of the fibrinogen molecule in continual motion from the time during which it is synthesized till the time when it is broken down through one or other of its several possible catabolic pathways. Also, this requires, because of the resulting clarification—and perhaps some readers may think this unfortunate—the use of some elementary mathematics of rate processes, which we try to keep as simple as possible and the use of which is

---

*Department of Medicine, University of Colorado Medical Center and the Veterans Administration Hospital, Denver, Colo.*

*Preparation of this review and work of the authors was supported by grants RR-51 from the General Clinical Research Centers Program of the Division of Research Resources, National Institutes of Health; HL-02262 from the National Heart Institute, two grants from the Colorado Heart Association, Denver, Colo.; Research Career Development Award AM 19578, Veterans Administration Research Allocation 554-01-2920.01-170,01 and a grant from the Milheim Foundation for Cancer Research, Denver, Colo.*

illustrated by diagrams. After presenting an account of the physiology and pathophysiology of fibrinogen behavior, we consider the relation of this to a number of human diseases.

### THE FIBRINOGEN SYSTEM: OVERVIEW

In describing fibrinogen behavior it is helpful to picture a fibrinogen system, that is a collection of physiologic components that are responsible for this behavior. It will be seen below that this system actually includes several subsystems. A flow diagram of the fibrinogen system, consisting of a collection of rectangles connected by arrows, is shown in Fig. 1. The arrows show paths of flow, while the rectangles represent compartments. The word "compartment" is very loosely used so instead of trying to define it we will describe what each of the rectangles represents. The

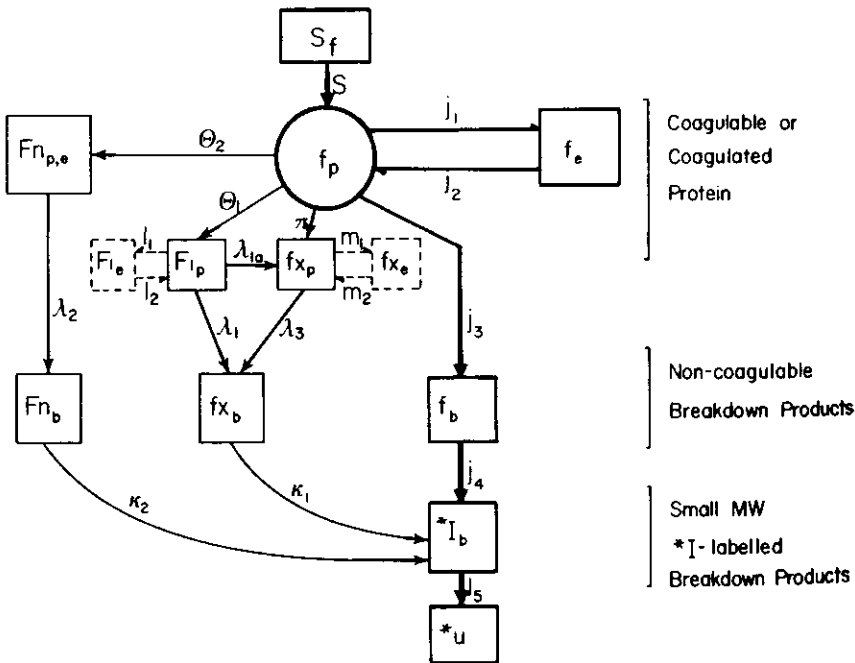

FIG. 1.: Synthesis, metabolism and distribution of fibrinogen (excluding platelet fibrinogen). A compartmental model is shown. Symbols:  $f$  = fibrinogen;  $F_1$  = fibrin monomer;  $F_n$  = fibrin polymer;  $f_x$  = first plasmin degradation product, X, of  $f$ ;  $S_f$  = fibrinogen synthetic apparatus synthesizing at a rate  $S$ . Subscripts  $p$  = plasma,  $e$  = interstitial fluids,  $b$  = breakdown sites and/or products (see text). Rate constants or parameters:  $j_1, j_2, j_3, j_4, j_5$ , define "core" fibrinogen and \*I-fibrinogen distributive and catabolic paths;  $\lambda_1, \lambda_2$  and  $m_1, m_2$ , define distributive paths of fibrin monomer and Fragment X, respectively. Greek letters define enzymatic paths,  $\theta_1$  and  $\theta_2$  of thrombin,  $\pi$  of plasmin,  $\lambda_1, \lambda_{1a}, \lambda_2, \lambda_3$  lytic paths of perhaps several enzymes and  $\kappa_1, \kappa_2$  final catabolic paths releasing \*I<sub>b</sub>. \*I<sub>b</sub> is the collection of radioactive iodide and \*I-labelled low molecular weight substances finally liberated by catabolism of \*I-f and its products. \*u is the \*I<sub>b</sub> excreted into the urine at a rate  $j_5$ \*I<sub>b</sub>. The core fibrinogen system is indicated by heavy lines.

rectangle  $S_f$  represents all the molecular mechanisms of the hepatocyte, with their associated biochemical compounds responsible for the synthesis of fibrinogen. It also includes the hepatocellular architecture through which the fibrinogen molecule must pass before entering the blood stream. The arrow  $S$  represents the secretion rate of fibrinogen, that is the rate at which fibrinogen is being secreted into the blood stream at some specified time in units of mg fibrinogen per day. Fibrinogen is continually secreted into the plasma to form plasma fibrinogen,  $f_p$ . In the plasma,  $f_p$  is continually mixed as a result of the different path lengths through the various circulatory beds, mixing being complete in a few minutes following an intravenous injection. To be on the safe side, a sample withdrawn ten minutes after an intravenous injection of a labelled protein is taken as completely distributed through the circulating blood [78]. Plasma fibrinogen continually leaves the blood stream 1) to enter the interstitial fluids and 2) to be catabolized at least mainly at unknown sites through unknown biochemical mechanisms and pathways. Interstitial fluid fibrinogen, which in our model is all lumped together as  $f_e$ , is continually returned to the blood stream. The compartment containing  $f_p$  is lined by vascular endothelium. Therefore exchange of  $f_p$  with extravascular compartments requires passage through capillary or venular endothelium into the interstitial fluids. Return of interstitial fibrinogen,  $f_e$ , to the plasma may occur to a small extent by reverse passage through the capillary endothelium, but takes place primarily through the lymphatics [205]. In Figure 1,  $f_p$  leaves at a rate  $j_1 f_p$  mg/day to enter the interstitial fluids where it becomes interstitial fluid fibrinogen,  $f_e$ . Interstitial fluid fibrinogen is returned at a rate  $j_2 f_e$  mg/day to the plasma. Main catabolism of fibrinogen is pictured in Fig. 1 as occurring in a breakdown compartment  $f_b$ , into which plasma fibrinogen destined for catabolism enters at a rate  $j_3 f_p$  mg/day and in which  $f_p$  is broken down to small peptide or amino acid catabolic products. The compartments and their contents that we have described so far, namely  $f_p$ ,  $f_e$ , and  $f_b$ , with their connecting flow parameters  $j_1$ ,  $j_2$  and  $j_3$  describe the primary paths and rates of fibrinogen distribution and metabolism in health. To show their primary importance these are depicted in Figure 1 with heavy lines. Below we call this the core fibrinogen system. However, the main function of fibrinogen is temporary sealing of vascular holes by fibrin formed through the action of thrombin on fibrinogen, and the duration of sealing is determined by the onset of fibrinolysis. Therefore, subsystems of fibrinogen metabolism dependent on the clotting and fibrinolytic enzymes need to be considered. Figure 1 includes three such subsystems and these are outlined by narrower lines. In the first, a fraction of plasma fibrinogen, which in health is very small is transformed into fibrin monomer,  $F1$ , at a rate  $\theta_1 f_p$  through the action of thrombin generated in the blood stream [147].  $F1$ , either free or combined with fibrinogen and perhaps cold insoluble globulin [239, 242], circulates in the plasma as  $f1_p$ , and in Fig. 1 we presume it is exchanged with interstitial fluid fibrin monomer  $F1_e$  at rates given by  $\theta_1 f1_p$  and  $\theta_2 F1_e$  mg/day. The broken line rectangle encircling  $F1_e$  indicates that this is an assumption.  $F1_p$  is removed from the plasma at a rate  $\lambda_1 F1_p$  to be catabolized in the breakdown compartment,  $f_x$ , which it shares with  $f_x$  (see below). Also a portion of  $F1_p$  is transformed to plasma fragment X,  $f_x$ , at a rate  $\lambda_{1a} F1_p$  [137]. A second subsystem consists of fibrinogen removed from the plasma at a rate  $\theta_2 f_p$  to become fully polymerized fibrin when exposed to the action of the crosslinking

enzyme fibrinolyase (Factor XIII) [63]. This might occur within blood vessels,  $F_{n_p}$ , or extravascularly in tissue fluids,  $F_{n_e}$ . Though the behavior of crosslinked fibrin,  $F_n$ , in the two sites may be quite different; in Figure 1 all  $F_n$  is lumped together in a single compartment  $F_{n_{p,e}}$ , and  $F_{n_{p,e}}$  is pictured as entering a breakdown compartment  $F_{n_b}$  at a rate  $\lambda_2 F_{n_{p,e}}$ . In this compartment it may be catabolized by enzymes of the plasmin system [152], by lysosomal cathepsins [85] or by other proteases. Finally a third subsystem, which has been claimed to be responsible for as much as one-quarter of fibrinogen catabolism in health [167, 242, 243], depends on the action of circulating plasmin, either free or combined with  $\alpha_2$ -macroglobulin protease inhibitor [87] on plasma fibrinogen. Plasmin lyses plasma fibrinogen  $f_p$  into the clottable fragment X [137] at a rate  $\pi f_p$ . This clottable fragment in the plasma in amount  $fx_p$  is then presumed distributed to the interstitial fluids at a rate  $m_1 fx_p$  mg/day, where it becomes interstitial clottable Fragment X in amount  $fx_e$ , and is presumed returned to the plasma at a rate  $m_2 fx_e$  mg/day. Again this presumption is indicated by a broken line compartment surrounding  $fx_e$ . Plasma X fragment also continues its metabolic breakdown through the sustained action of plasmin to become the nonclottable Fragments Y, D and E [137], and the rate of entry into the breakdown compartment  $fx_b$  in which this occurs is described by  $\lambda_3 fx_p$  mg/day. Figure 1 presents a minimal model of the plasma fibrinogen system. We now ask: How can this system be studied, what is known about the physiology and pathophysiology underlying this system, and in what ways does current information bear on the understanding and treatment of diseases of the fibrinogen system?

Study of the fibrinogen system is conveniently divided into two parts, the first concerned with the synthesis and secretion of fibrinogen, the second with the remainder of the system of Figure 1. It is convenient to deal with the latter first.

## STUDY OF THE DISTRIBUTIVE AND CATABOLIC PARTS OF THE FIBRINOGEN SYSTEM

### The Use of \*I-Labelled Fibrinogen

Let us first examine the equations of the core of the fibrinogen system omitting those parts of the system determined by plasma enzyme actions. The differential equations are [10]:

$$\begin{array}{ll}
 1) \quad df_p/dt = S + j_2 f_e - (j_1 + j_3) f_p & f_p(0) \text{ required for solution of} \\
 & \text{equations 1) and 2) is measured} \\
 & \text{at zero time.} \\
 2) \quad df_e/dt = j_1 f_p - j_2 f_e & f_e(0) \text{ is calculated from } j_1 f_p(0)/j_2.
 \end{array}$$

In a steady or equilibrium state, evidence of which would be a constant plasma fibrinogen level,

$$df_p/dt = df_e/dt = 0, f_p \text{ and } f_e \text{ are constant and } j_1 f_p = j_2 f_e.$$

$$\text{Hence } S = j_3 f_p.$$

To solve Equations 1 and 2 in a steady state we then need to know  $f_p(0)$ ,  $j_1$ ,  $j_2$ ,  $j_3$  which allows us to calculate  $f_e$  from Equation 2 and  $S$  from Equation 1. We obtain  $f_p$ , total plasma fibrinogen, from plasma volume multiplied by plasma fibrinogen concentration. Values for  $j_1$ ,  $j_2$  and  $j_3$  are obtained from studies with a good radioactive iodine ( $^*I$ ) labelled fibrinogen. If this closely mirrors the behavior of native fibrinogen and only the radioactive fibrinogen is studied Equations 1 and 2 become

$$3) \quad d^*f_p/dt = j_2^*f_e - (j_1 + j_3)^*f_p$$

$$4) \quad d^*f_e/dt = j_1^*f_p - j_2^*f_e$$

where the asterisk indicates  $^*I$ -labelled fibrinogen, and  $^*I$  is radioactive iodine. For solution of Equations 3 and 4 it is necessary that  $j_1$ ,  $j_2$ , and  $j_3$  be constants and that  $^*f_p$  should be measured, or failing this that other information should be available [46]. Fortunately it turns out that within the errors of measurement  $j_1$ ,  $j_2$  and  $j_3$  in health and in most diseases behave as constants [10] (and see later).

Other valuable information is available about the core of the fibrinogen system. First we can measure the radioactive iodide and small molecular weight  $^*I$ -labelled end products of  $^*I$ -protein catabolism released into compartment  $^*I_b$  of Figure 1. Total  $^*I_b$  at time  $t$  is given by the plasma concentration of these labelled end products multiplied by their distribution volume [10]. The plasma concentration is determined from the radioactivity remaining in the supernatant after removing plasma proteins with protein-precipitating agents. Secondly, we can measure the cumulative rate of excretion of radioactive end products in the urine which enter from  $^*I_b$ . Fortunately this includes almost all radioactive end products [21, 260]. If urine collections are complete, which is not always easy to achieve,  $^*f_p(0)$ , the initial quantity of radioactive iodine attached to fibrinogen that was injected, less  $^*u(t)$ , the cumulative urinary excretion of radioactivity from the time of injection to time  $t$ , gives an estimate of the sum of all forms of radioactivity remaining in the animal or subject at time  $t$ . An alternative method of making the same measurement is to use a whole body counter for either animals [13, 41] or man [230]. With animals, care has to be taken that they do not accumulate some urine radioactivity on their fur. Lastly, sites of accumulation of radioactive iodine either bound to fibrinogen, fibrin or their degradation products or in the form of small molecular weight labelled substances can be localized and sometimes their  $^*I$  content can be estimated by radioactive scanning. The above methods of obtaining extra information about the behavior of the core fibrinogen system allow tests of how good the fit of the model equations is to the experimental data. The evidence is that both in animals [10] and man [52, 255], the equations of the core model fit the experimental data in health and in a number of other states [12, 13, 254, 257, 258, 267] quite well.

#### Requisites for Satisfactory Studies with $^*I$ -Proteins

Reliable studies with  $^*I$ -labelled proteins require 1) preparation of a fairly pure (95% or better) undenatured protein, 2) a precise method of measuring the

protein's concentration in plasma, 3) labelling the protein with radioactive iodine without denaturation, 4) an adequate quantitative model of the protein's metabolism and distribution. Since one or more of these requirements are frequently neglected in studies with <sup>\*</sup>I-proteins, we now review current knowledge with particular reference to fibrinogen and its products.

#### *Fibrinogen Preparation*

It is general experience that for metabolic studies proteins are best prepared by the mildest methods possible, such as salt fractionation and gel filtration, and that methods such as organic solvent fractionation and ion exchange chromatography are likely to lead to altered biological behavior. In our view, commercially available preparations of proteins should never be used for metabolic experiments. We prepare fibrinogen of 95% clottability or better by salt fractionation and remove fibrin monomers by treatment with low ionic strength buffers in the cold [11]. McFarlane and coworkers [142] also use salt fractionation [119] but early ran into trouble with fibrin monomers [213]. Other investigators have used organic solvent precipitation for preparation of fibrinogen and its lysed products [242, 243], which makes one examine their findings with caution.

#### *Plasma Fibrinogen Concentration Measurement*

Standard methods depend on clotting fibrinogen with bovine thrombin, separating the clot from contaminating proteins and, after solution, measuring its protein content by its ultraviolet absorption [26], by reacting it with the tyrosine reagent [201] or by drying and measuring weight [193]. Errors arise 1) from presence of contaminating proteins in the clot, 2) in obtaining quantitative recovery of the clot before measuring its protein content; e.g. from destruction of the clot by fibrinolysis or loss of clot fragments during its separation. We have developed an accurate isotope dilution method [11] which, though tedious, avoids these problems. Fibrinolysis can be inhibited by the addition of  $\epsilon$ -aminocaproic acid [152] and/or soya bean trypsin inhibitor or Traysol to the plasma [30, 52]. In general, other methods of measuring fibrinogen concentration are not sufficiently reproducible for use. These include heat precipitation, nephelometry and volumetric measurement of the clot after recalcification. Semiautomated methods have been developed [128], and these are subject to errors 1) and 2) above. Electroimmunoassay [127] may provide sufficient accuracy. It should be noted that with the thrombin clotting methods, all protein will be measured that clots and that is included in the clot. Thus fibrin monomer, F1, and fibrinogen Fraction X of approximately 270,000 MW [137] will be measured as fibrinogen. With electroimmunoassay, all proteins with antigenic determinants that react with the antibody to fibrinogen will be determined.

#### *Satisfactory Labelling of Fibrinogen with Radioactive Iodine*

A number of methods of labelling have been proposed [21, 143], and the chemistry of the iodination of protein has been well described [103]. The currently popular methods are the iodine monochloride method [141], the chloramine T method [104], the electrolytic method [192] and the leucoperoxidase meth-

od [136]. Very recently, a new method dependent on conjugating an \*I-labelled small molecular compound to the protein has been proposed [33]. Of these, the first appears the mildest and the least destructive to fibrinogen [122], the second appears too destructive, while the third presents special problems.

Tests of the behavior of \*I-fibrinogen may be made by comparing it with that of an isolated <sup>14</sup>C-labelled fibrinogen prepared *in vivo* [41, 142] or with \*I-fibrinogen "screened" by prior injection into a screening animal [142]. After this animal, over the next 24 to 48 hours, has removed by reticulo endothelial cell reaction the denatured or otherwise altered \*I-fibrinogen from the plasma, the animal is bled and the \*I-fibrinogen in the separated plasma is injected into the experimental animal [142]. The above tests are only suitable for experimental animals. Altered labelled proteins show an increased rate of catabolism during the first day or two after injection [145]. This results in an increased clearance rate of damaged \*I-protein from the plasma, with an increased rate of release of nonprecipitable radioactive iodide into the \*I<sub>b</sub> compartment [145]. This is then excreted into \*u, Figure 1. Measurement of a "hump" in the concentration of plasma \*I not precipitated by protein precipitants [145], or an excess rate of \*I-excretion in the urine during the first 48 hours after injection, indicates the presence of an unacceptable amount of altered \*I-labelled protein [145]. Phosphotungstic acid [145] and 20% trichloroacetic acid [213] seem to be the protein precipitants of choice. These tests can be applied to studies in man. McFarlane [142] showed that rabbit fibrinogen labelled with more than an average of 0.5 atom I per fibrinogen molecule decayed in the plasma at a faster rate than the screened material. Thus, though this was perhaps not found to be true for human fibrinogen [27], it is now the general practice to label fibrinogens at a level less than this. Even heavy labelling with iodine has very little effect on fibrinogen clottability [213]. The fibrinopeptides released from fibrinogen by thrombin [169] and some other proteases [169] contain tyrosines that in some species are labelled during fibrinogen iodination. This is true of dog [28, 216], but not of man or rabbit [216]. In species in which this occurs, if plasma is clotted and the clot is washed before measurements of radioactivity are made, significant losses of radioactivity will occur. This complicates the metabolic interpretation of \*I-fibrinogen studies. A number of potentially very useful studies have been made in dogs [58, 178] and these and others are referred to later. It is our feeling that the fibrinogen molecule, whether \*I-labelled or not is quite delicate. This may be partly due to its propensity to accompany plasminogen or adsorb to plasmin [259] during purification. Thus we take great care with our preparations for metabolic experiments, handle them very gently in the cold, particularly avoiding vigorous stirring, and after completing preparations, store them in the cold for at most 0.5 to 1.0 day before injecting them. They are sterilized by passage through a millipore filter in the presence of carrier plasma or albumin [255].

#### *Quantitative Models of Plasma Protein Metabolism*

Interpretation of \*I-labelled plasma protein data depends on an adequate quantitative model appropriate to the particular protein under study. This needs to be sufficiently realistic to provide satisfactory measurements but not so complex in its attempt to match exactly the real system that it becomes unusable. The only

way of testing a model is by comparing its predictions with measurements and accepting it if agreement meets previously defined standards and if the model equations describe at least approximately physiologic or pathophysiologic reality. The models describing plasma \*I-protein behavior all depend on some form of compartmental analysis [20]. A number of papers and books [15, 223] give good descriptions of this. The following papers are perhaps particularly helpful for models of fibrinogen behavior [10, 52, 140]. Compartmental analysis generally assumes that a system can be described by linear differential equations with constant coefficients, such for instance as Equation 1 above. These equations are particularly easy to solve, for instance manually by using Laplace transforms [248], or on an analog computer [105] or on a digital computer programmed to solve these equations by mimicking an analog computer [130]. We use the MIMIC program of the CDC 6400 digital computer [130]. Other similar programs are available for other makes of digital computers. We now repeat and examine Equations 3 and 4 above to throw light on the underlying assumptions of compartmental analysis:

$$3) \quad d*f_p/dt = j_2 *f_e - (j_1 + j_3) *f_p \quad \text{given } *f_p(0) = \text{a measured value}$$

$$4) \quad d*f_e/dt = j_1 *f_p - j_2 *f_e \quad \text{given } *f_e(0) = 0.$$

Reference to Figure 1 shows that over a time interval,  $\Delta t$ ,  $d*f_p/dt$ , the rate of change of plasma \*I-fibrinogen depends on the rate of inflow  $j_2 *f_e$  of interstitial fibrinogen, less the summed rates of outflow of plasma \*I-fibrinogen across the capillary membrane,  $j_1 *f_p$ , and to catabolic sites,  $j_3 *f_p$ .

Accepting for the moment that plasma \*I-fibrinogen and interstitial \*I-fibrinogen can be reasonably represented as the rapidly mixed single pools,  $*f_p$  and  $*f_e$ , then over a sufficiently short interval  $j_1$ ,  $j_2$  and  $j_3$  can be accepted as constants, and thus over this interval, Equations 3 and 4 become first order linear differential equations with constant coefficients. The question is how long do  $j_1$ , fractional transcapillary transfer rate,  $j_2$ , fractional lymphatic return rate, and  $j_3$ , fractional catabolic rate, remain constant. The general solution of Equation 3 with constant coefficients is  $*f_p = C_1 e^{-a_1 t} + C_2 e^{-a_2 t}$  and of Equation 4,  $*f_e = C_3 (e^{-a_1 t} - e^{-a_2 t})$ . In practice in healthy animals and men, and in many abnormal states, it is found that measured  $*f_p$  can be matched quite closely by  $C_1 e^{-a_1 t} + C_2 e^{-a_2 t}$  over seven days or so [10], when these parameters are derived by computer [13] or other curve fitting. Though it is known that return rate of interstitial protein in lymph and thus  $j_2$  may vary during the day and this might also be expected for  $j_1$ , the above findings imply that, on the average, when considering the slow fibrinogen system,  $j_1$ ,  $j_2$  and  $j_3$  remain fairly constant over seven days. Once the values of the C's and a's are obtained, values of  $j_1$ ,  $j_2$  and  $j_3$  are derived from combinations of these values [10]. Also, subject to restrictions mentioned later,  $j_3$  can be estimated from urinary \*I excretion over an interval, and mean plasma \*I-fibrinogen in that interval [10]. It was noted above that in Equations 3 and 4,  $*f_p$  and  $*f_e$  are pictured as single pools of labelled fibrinogen mixed rapidly, as compared with the slow time constants of the fibrinogen system. Though true of plasma fibrinogen, this cannot be true of interstitial fibrinogen distributed discretely as it is in many



different tissues. However, the same mathematical equation may describe different models and it turns out that Equation 4 not only describes the behavior of interstitial fibrinogen if it was distributed in a single rapidly mixed pool, but also if it left the capillary endothelia in a series of minute streams that wandered through the tissue fluids and returned by the lymphatics over a range of times described by  $e^{-j_2 t}$  [204, 205]. The latter provides a realistic description of a likely behavior of interstitial fibrinogen [205]. The precision of measurement of  $j_1$ ,  $j_2$  and  $j_3$  depends on the precision of measurement of the C's and a's. Experiments on rabbits show that plasma \*I-fibrinogen activities can be measured with a coefficient of variation of 2% [46]. This allows calculation of the effects on the C's and a's and on the calculated values of the j's of the random variations in measured \*I-fibrinogen. Studies show that, whereas  $C_1$ ,  $C_2$  and  $a_1$  can be estimated with reasonable precision,  $a_2$  is estimated with much less precision. As a result,  $j_3$  can be measured with precision, but random small errors in measurement lead to coefficients of variation of about 30% in measurements of  $j_1$  and  $j_2$  and about 20% for  $j_1/j_2$ . Others have made similar observations [197]. Since  $j_1$  and  $j_2$  represent real physiologic parameters, the best estimate is to take means of several studies [46]. Table 1 gives representative normal values for several species for the core model rate constants, the plasma radioactivity half-life, the plasma fibrinogen concentration, the mass ratio of extra- to intravascular fibrinogen, and the catabolic efflux.

#### STUDIES BEARING ON THE ANATOMY AND PHYSIOLOGY OF THE FIBRINOGEN CORE SYSTEM

Newly synthesized fibrinogen has been shown to be secreted directly into the blood stream and only to a small extent into the hepatic duct lymph [228]. When fibrinogen enters the blood stream, it is immediately exposed to the dangers of transformation by circulating enzymes, particularly serine proteases. That is, the subsystems  $\theta_1$ ,  $\theta_2$ , and  $\pi$  may become activated. The most important enzymes are thrombin, which splits off peptides A and B by attacking specific arginyl-glycine bonds [134], plasmin, which progressively degrades fibrinogen or fibrin into smaller fragments by attacking some arginyl or lysyl peptide bonds [225] and trypsin, which attacks L-arginyl and L-lysyl peptide bonds [273]. Other proteases, e.g., elastase, may also be involved. To prevent generalized coagulation or generalized fibrinogenolysis or fibrinolysis evolution has provided complex but not always effective mechanisms. Thrombin circulates as prothrombin in precursor form and when released reacts with antithrombins, particularly  $\alpha_2$ -macroglobulin [3, 279] and antithrombin III [93, 227]. The reactions with antithrombin III in blood appear slow [2]. Plasmin also circulates as plasminogen in precursor form and, when released, is neutralized by antiplasmins, particularly  $\alpha_2$ -macroglobulin and  $\alpha_1$ -antitrypsin [167]. If trypsin enters the circulation, this also reacts with antitrypsins, particularly  $\alpha_2$ -macroglobulin and  $\alpha_1$ -antitrypsin [185]. Thus, these circulating proteolytic enzymes have their attack on fibrinogen limited by combination with antiproteases. Many of these antiproteases are  $\alpha$ -globulins containing fairly high proportions of carbohydrates [93]. Current evidence is that they form covalent bonds with the inactivated enzymes in the region of the enzyme active site and that

TABLE 1. Representative Normal Parameters of Fibrinogen Metabolism

	<i>n</i>	$j_1$ days <sup>-1</sup>	$j_2$ days <sup>-1</sup>	$j_3$ days <sup>-1</sup>	$t_{1/2}$ days	<i>c</i> mg/ml	$f_p$ mg/kg	$f_e/f_p$	$j_3 f_p$ mg/kg/day
Man									
Takeda [255]	12	.548 ± .089*	2.99 ± .51	.246 ± .005	3.36 ± .07	3.60 ± .14	127 ± 5	.188 ± .013	31.3 ± 1.4
Collen, et al [53]	35	.60 ± .04	1.02 ± .07	.24 ± .01	4.14 ± .09	2.84 ± .12	119 ± 7	.39 ± .01	28 ± 2
Regoeczi, et al [213]	33†	.453 ± .043	—	.231 ± .005	—	—	—	.235 ± .005	33.7 ± 1.9
Monkeys									
Regoeczi, et al [217]	8	—	—	.513 ± .013	1.75 ± .08	2.75 ± .12	95 ± 3	.28 ± .01	48.7 ± 2.4
Dogs									
Tytgat, et al [266]	16	.79 ± .11	1.36 ± .28	.39 ± .01	2.54 ± .06	3.16 ± .26	168 ± 10	.39 ± .01	58 ± 6
Rabbits									
(older) Atencio, et al [10]	7	.51 ± .15	2.03 ± .41	.37 ± .03	2.40 ± .09	3.49 ± .18	106 ± 6	.24 ± .03	38 ± 2
(young) Atencio, et al [10]	7	.97 ± .19	2.22 ± .39	.44 ± .02	2.24 ± .08	3.14 ± .17	113 ± 6	.43 ± .03	50 ± 4
Rats									
Ruckdeschel, et al [236]	28	—	—	.71 —	.98 —	2.03 —	71 —	—	65 —

\*Standard error of the mean.

†From various authors; includes Takeda's 12 patients [255].

$j_1$  is the fractional transcapillary rate,  $j_2$  the rate of lymphatic return to the plasma, and  $j_3$  the fractional catabolic rate.  $t_{1/2}$  is the half life of plasma radioactivity after the first 24-48 hours. *c* is the plasma fibrinogen concentration,  $f_p$  the intravascular fibrinogen mass and  $f_e/f_p$  the mass ratio of extra- to intravascular fibrinogen.  $j_3 f_p$  is the amount of intravascular fibrinogen catabolized each day.

the reactions are irreversible [93, 279]. The complexes then seem to be rapidly removed from the circulation [53, 73, 185]. To what extent these circulating proteases are active in health on circulating fibrinogen is a matter of controversy and not easy to resolve experimentally. For instance, it has been claimed that, on the average, 6% of "fibrinogen" separated from rabbit plasma is in the form of fibrin monomer, while 13% is in the form of the clottable plasmin digestion product of fibrinogen, Fragment X [242]. These claims depend on separation of fibrinogen from fresh or stored blood [242, 243]. The chemical techniques are complicated and take a considerable time. They involve beta alanine and glycine precipitations interspersed with cold ethanol treatment [242, 243]. Whether the final products obtained are actually circulating in the living blood stream, or whether they are formed following prothrombin or plasminogen activation during blood withdrawal or processing or during the chemical separations, or even induced by the chemical separations, is not clear. Inactivation of inhibitors by organic solvents may also permit persistence of activated serine proteases [165].

The effect on \*I-fibrinogen studies of Sherman's [242] and Mossesson's [167] claims that 25% of plasma fibrinogen may normally be degraded by the plasmin,  $\pi$ , pathway and that Fragment X so formed has a  $t_{1/2}$  of 26 hours is assessed in Figure 2. This presents simulation studies of thrombin-clottable "I-fibrinogen" curves, which include \*I-fibrinogen,  $*f_p$ , and \*I-Fragment X,  $*fx_p$ : 1) if 100% of the labelled material injected at zero time into the blood is normal \*I-fibrinogen—curves 1 and 2—and 2) if 75% injected is normal \*I-fibrinogen and 25% is \*I-Fragment X—curve 3. In all three curves, the two thrombin paths are closed and  $\theta_1 = \theta_2 = 0$ . Curve 1 shows the normal disappearance of plasma \*I-fibrinogen if the plasmin path  $\pi$  is closed. Curves 2 and 3 show the disappearance of \*I-clottable protein if the plasmin path is open, and 25% of the \*I-fibrinogen is degraded by this path. Further information is given in the figure legend. The paradoxical findings are that longer half-lives of "\*I-fibrinogen" may occur when the plasmin path is open than when it is closed. These findings might explain some of the reported longer half-lives of \*I-fibrinogen.

Recently Nossel and collaborators [180] and Collen and collaborators [51] have provided evidence suggesting that, in healthy men, only very small amounts of fibrinogen are degraded by the thrombin or plasmin paths. Thus the normal levels of human plasma fibrinopeptide A indicate that only 2-3% of fibrinogen is degraded by thrombin [180], while less than 5% of fibrinogen is degraded by plasmin paths [51]. We, therefore, for the present prefer to exercise caution in assuming that the clottable protein of the healthy animal's plasma contains more than a very small amount of fibrin monomer or Fragment X, and that the enzymatic pathways labelled  $\theta_1$ ,  $\theta_2$  and  $\pi$  play any more than a minimal role in normal fibrinogen catabolism.

Astrup suggested some years ago that continuous thrombin-mediated fibrin deposition on the surface of vessels followed by rapid fibrinolysis could promote vascular repair and account for much of normal fibrinogen catabolism [9]. The above studies show that, if this occurs, only a very small amount of normal fibrinogen catabolism is involved, and this fits in with conclusions in Bocci's review [29]. However, plasma fibrinogen is important to the circulation, in that it confers stickiness on red cells (thus increasing the erythrocyte sedimentation rate)

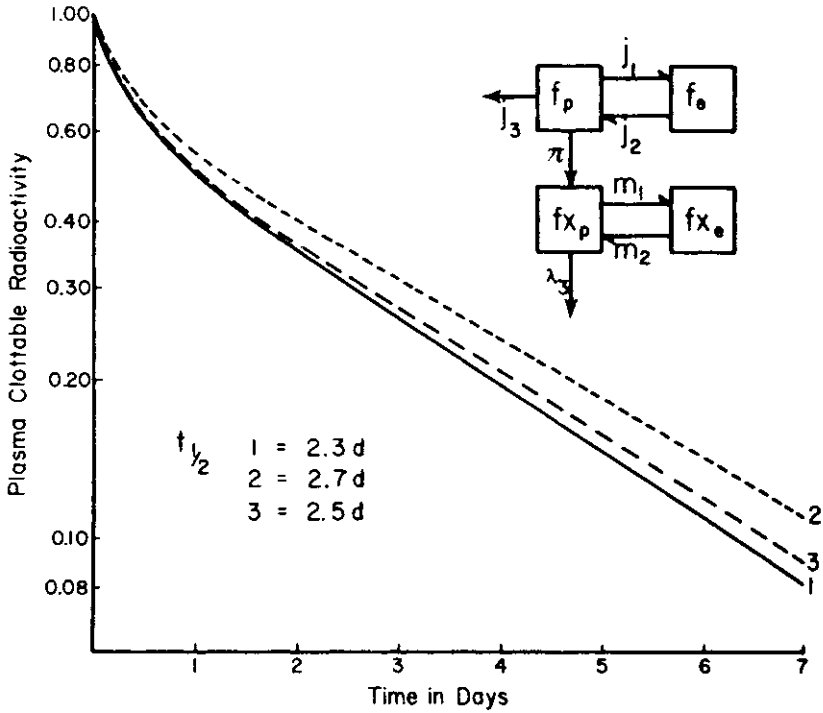

FIG. 2: Effects of opening the plasmin path in a healthy young rabbit. Simulations on a digital computer of the plasma clottable \*I-fibrinogen  $f_p$  in a young rabbit when  $\theta_1 = \theta_2 = \pi = 0$ ,  $j_1 = .97 \text{ day}^{-1}$ ,  $j_2 = 2.22 \text{ day}^{-1}$ ,  $j_3 = .44 \text{ day}^{-1}$  [10], Curve 1. Curves 2 and 3 show the effects of  $\pi = .25 (\pi + j_3)$ ,  $\pi + j_3 = .44$ ,  $\theta_1 = \theta_2 = 0$ ,  $m_1 = .97 \text{ day}^{-1}$ ,  $m_2 = 2.22 \text{ day}^{-1}$  in a similar young rabbit. It is assumed that  $m_1 = j_1$  and  $m_2 = j_2$  because of the similar sizes of fibrinogen and Fragment X. In this animal,  $f_x$  has a half-life of 26 hrs [242], and  $\lambda_3$  is estimated at  $.027 \text{ day}^{-1}$ . Curve 2 shows initial content of  $f_p$  entirely as normal high molecular weight fibrinogen. Curve 3 shows initially 75% high molecular weight fibrinogen,  $f_p$ , and 25% Fragment X  $f_x_p$ . Note the paradox that opening the plasmin  $\pi$  path slows down the  $t_{1/2}$  of the plasma clottable protein. Thus, for the slow slopes,  $t_{1/2}$  was 2.3 days for Curve 1, 2.7 days for Curve 2, and 2.5 days for Curve 3.

and its concentration is directly related to the blood viscosity [48, 153]. Surprisingly, it has also been claimed that resistance to blood flow through a vascular bed is reduced by the presence of fibrinogen [44].

Apart from attack by circulating enzymes, fibrinogen is exposed to two other fates. It may pass through permeable vessels to enter the interstitial fluids, or it may pass to catabolic sites. Rate of passage of macromolecules to the interstitial fluids is inversely proportional to molecular size [81] so that, for instance, fibrinogen passes to the interstitial fluids more slowly than the 68,000 MW albumin. Also, the permeability of capillary beds varies. The most permeable vessels are found in the viscera, the least permeable in the skin and muscles [81]. Possible sites of transcapillary passage are capillary fenestrae or large pores typically seen in the intestine [50]; intercapillary-endothelial cellular junctions that seem to be tightly closed by zonulae occludentes and are typically seen in skin and muscle

capillaries [37, 38] and large interendothelial gaps as chiefly seen in the liver sinusoids. Consider for the moment the transcapillary passage of the smaller albumin molecule. Though liver sinusoid and intestinal capillary pores may account for albumin passage to the interstitial fluids and lymph in these sites, capillary endothelial pores cannot account for passage elsewhere. Instead, for a variety of regulatory and other reasons [205], passage through capillary endothelia outside the viscera seems to demand carriage in endothelial vesicles 500-1000 Å in diameter. These are found in capillary endothelia, some fused with the inner and others with the outer margin and seem by pinocytosis to transport fluid globules between the two surfaces [38, 240]. As noted above, studies with <sup>125</sup>I-labelled proteins allow the distribution of passage times through the interstitial fluids to be determined [204]. This is governed by 1) the density of the sites of entry into the interstitial fluids of each tissue and 2) the random passage of the protein molecules carried by diffusion and fluid flow through the interstitial fluids and lymphatic system [228]. The pattern of passage times for fibrinogen in both man and rabbit differs from that for albumin. Whereas a significant fraction of the albumin passage times last over several or many days and these contain the main bulk of interstitial albumin, such fibrinogen paths are absent [204]. The long albumin paths on other evidence probably represent the albumin primarily distributed in skin and muscle which must therefore contain little fibrinogen. Thus the interstitial content of fibrinogen is proportionately much less than that of albumin. These findings suggest that, in keeping with its larger molecular size, interstitial fibrinogen is primarily distributed in the small volume rapid flow interstitial fluids of the viscera, which contribute 70% of the thoracic duct lymph flow. Thoracic duct fibrinogen concentration is 30 to 50% of plasma fibrinogen concentration [17]. Although fibrinogen has been demonstrated in tissue fluids by fluorescent-labelled antifibrinogen antibody [74], in general our knowledge of the ultrastructure of the interstitial fluid milieu and the behavior of fibrinogen in it is very sparse. Elsewhere, an examination of some features of it, which seem essential for regulation of levels and content of interstitial protein, has been made [204].

The second fate of circulating fibrinogen is catabolism, which seems to occur quite rapidly and, on the basis of knowledge of albumin, involves destruction of the (labelled) protein to catabolites the size of iodotyrosines [288]. If carefully prepared <sup>125</sup>I-fibrinogen is injected into the circulation of man or animal, there is quite rapid removal of the 1 or 2% which has been altered in a good preparation. <sup>125</sup>I-labelled small molecular weight substances are rapidly released into the plasma and body fluids and excreted into the urine [10]. There is much evidence that altered protein is rapidly taken up by the reticuloendothelial cells, e.g., the Kupffer cells [18], and is rapidly catabolized by them, probably by their lysosomal cathepsins. Studies by Freeman and coworkers [71] showed that rapid removal from the circulation was characteristic of proteins altered by several different forms of denaturation. After this phase, however, normal catabolism proceeds at a regular rate without any great delay between the time the <sup>125</sup>I-fibrinogen destined for catabolism leaves the circulation and the time catabolic products in the form of <sup>125</sup>I-iodide or <sup>125</sup>I-small molecular-weight catabolites enter the circulation [10, 21, 145]. Thus the breakdown compartment  $f_b$  is small and efficient. Further, in health and many diseases,  $j_3$ , the fractional breakdown rate, remains remarkably

constant and independent of plasma fibrinogen concentration [10, 215], even following intravenous infusions of large quantities of fibrinogen [13, 212], so that the normal catabolic mechanisms, which must be enzymatic, are not saturated by substrate. We do not know the location or the mechanisms of these catabolic sites. They are not in the blood cells because incubating  $^*I$ -fibrinogen with sterile blood does not lead to breakdown. They are possibly in capillary endothelium, which is rich in plasminogen activator [152]. If significant pinocytosis of drops of plasma occurred, plasminogen that tends to be associated with fibrinogen might well be activated, leading to fibrinogen digestion by plasmin in the pinocytotic vesicles. The synovium, a tissue resembling endothelium, may provide a model of catabolic sites. This apparently removes fibrinogen from the joint space without clot formation and without release of fibrinogen digestion products [88]. Several investigators have shown that enzymatic removal of carbohydrate from protein as by neuraminidase can alter catabolic rate of circulating proteins [29]. This is another possible step in the catabolic pathway of the fibrinogen core system, but so far has not been demonstrated to be important. For practical purposes our main conclusions can be that the site and mechanisms of the  $f_b$  compartment are presently unknown. In a steady state  $j_3 f_p = j_4 f_b$ , and so  $f_b = j_3 f_p / j_4$ . Since evidence is that  $j_4$ , the rate constant of breakdown, is large [209], then  $f_b$ , the fibrinogen being catabolized by the normal catabolic mechanisms at any one time is small [209]. Because of this, when considering rate of entry of  $^*I$ -labelled breakdown products into the body fluids and their excretion into the urine, the breakdown compartment,  $f_b$ , can be neglected, and it can be assumed that the fibrinogen destined for catabolism  $j_3 f_p$  is instantaneously broken down and the labelled breakdown products instantaneously enter the body fluid breakdown products compartment  $^*I_b$  [10].

### PATHOPHYSIOLOGY OF THE FIBRINOGEN SYSTEM

Before proceeding with this section it is necessary to examine the significance of  $\theta_1$ ,  $\theta_2$  and  $\pi$  and of  $\theta_1 f_p$ ,  $\theta_2 f_p$  and  $\pi f_p$ . In a linear system  $\theta_1$ ,  $\theta_2$  and  $\pi$  would be constants acting directly on the substrate  $f_p$ , total circulating fibrinogen. However,  $\theta_1$  and  $\theta_2$  are both functions of circulating thrombin level, while  $\pi$  is a function of circulating plasmin level. If  $\theta_1$ ,  $\theta_2$  and  $\pi$  reacted with plasma fibrinogen substrate according to Michaelis-Menten kinetics, then the reaction would be described as  $V = V_{\max} f_p / (K_m + f_p)$ , where  $V$  is the quantity of fibrinogen transformed into product in unit time,  $f_p$  is total circulating plasma fibrinogen,  $K_m$  is a modified Michaelis-Menten constant with dimension of mg plasma fibrinogen and  $V_{\max}$  is the maximum velocity obtainable for a given quantity of enzyme. This equation shows that if  $f_p$  is held constant, then  $V$ , the quantity of fibrinogen transformed is directly proportional to  $V_{\max}$ , which is in turn directly proportional to quantity of circulating thrombin or plasmin. In a simple system, provided plasma fibrinogen does not show much fluctuation, the fibrinogen reaction rates  $\theta_1 f_p$ ,  $\theta_2 f_p$  and  $\pi f_p$ , should be directly proportional to the quantities of circulating thrombin for the first two fluxes and of circulating plasmin for the third flux. If  $f_p$  shows considerable fluctuations because of removal of fibrinogen or increased fibrinogen synthesis, the kinetics become more complex because  $f_p$  varies. The

rates,  $V$ , then depend on the dual effects of fibrinogen concentration as shown by the Michaelis-Menten equation, and on the level of the circulating proteases as these affect  $V_{max}$ . Studies *in vitro* suggest that thrombin and plasmin kinetics are even more complicated [132, 190]. Also, the continual removal from solution in the plasma of the enzymes, as enzyme-inhibitor complexes, and of the substrates, as altered fibrinogen products, make the kinetics *in vivo* very complicated indeed. For this reason, below we only write generally about the  $\theta_1, \theta_2$  and  $\pi$  pathways involved. It will be seen that, in spite of the above complications, in a number of clinical and experimental situations,  $\theta_2$  and  $\pi$  seem to behave as if they are constants acting on total plasma fibrinogen.

Figure 3 presents the noncore part of the plasma fibrinogen system, which is known to be affected in disease. We note that the noncore paths leaving plasma fibrinogen depend on the two enzymes thrombin and plasmin. A therapeutic path depends on use of the venom enzymes Arvin and Reptilase for their action on circulating fibrinogen and is mentioned briefly below. We now dissect the thrombin and plasmin paths. If large but sublethal quantities of thrombin are released from circulating prothrombin, either by activation of the intrinsic or extrinsic systems, a

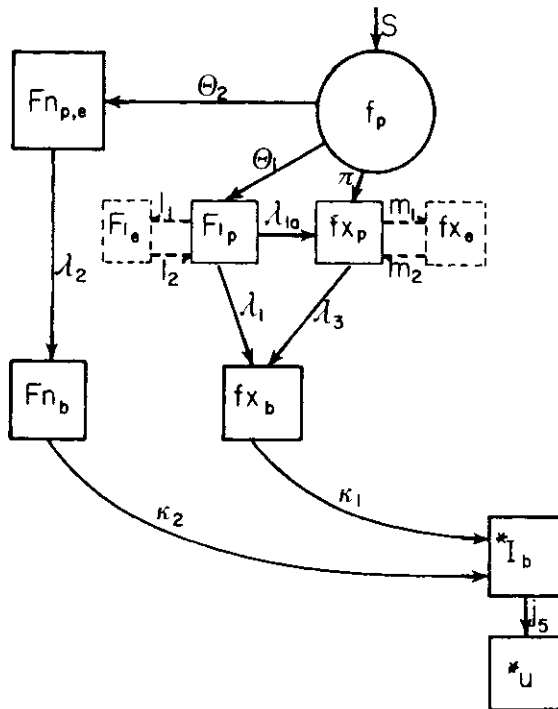

FIG. 3: The fibrinogen enzymatic paths. Synthesis, metabolism and distribution of fibrinogen, excluding the "core" fibrinogen system. For further description see the legend to Fig. 1.

characteristic series of events occurs similar to the clinical picture of acute disseminated intravascular coagulation [245]. Plasma fibrinogen initially falls, as do platelet and white cell counts [224]. Factors V and VIII fall and intravascular clotting occurs. After some delay, fibrinolysis from activation of plasminogen supervenes and plasma fibrin digestion products increase. Heparin blocks the development of the disturbance [177, 287]; but the disturbance is made worse or even lethal by injecting intravenously the plasma kallikrein inhibitor Trasylol [224] or  $\epsilon$ -aminocaproic acid (EACA) [245]. Both of these inhibit fibrino(genol)ysis and these findings indicate that fibrinolysis is an essential protective mechanism against the action of thrombin. There has only been one study of the fate of intravenously injected  $^{125}\text{I}$ -labelled thrombin [73]. This was removed quite quickly, perhaps into the reticulo-endothelial system and, as judged by the release of non TCA-precipitable radioactive iodides and small molecular weight  $^{125}\text{I}$ -labelled metabolites, was broken down quite rapidly. Thus, on current knowledge it would seem that thrombin causes intravascular clotting of fibrinogen over quite a brief time before it is removed from the circulation and broken down. The excellent studies of Ohlsson on the neutralization of circulating trypsin in dogs by  $\alpha_1$ -antitrypsin and  $\alpha_2$ -macroglobulin [185] probably throw light on thrombin-antithrombin reactions. Ohlsson showed that  $\alpha_2$ -macroglobulin reacts very rapidly with trypsin,  $\alpha_1$ -antitrypsin reacts more slowly. Both neutralize the proteolytic activities of the trypsin, and the trypsin complexes with both were rapidly removed from the circulating blood and broken down. We can presume that the reactions of thrombin with the circulating antithrombins  $\alpha_2$ -macroglobulin and antithrombin III are very similar, though almost nothing is known of the kinetics of these reactions and the rates of removal of the thrombin complexes from the living animal's circulation.

Studies have been made of the effects of thrombin infusion in dogs previously given  $^{125}\text{I}$ -fibrinogen [177, 287]. The general finding is that there is a rapid fall in plasma levels of fibrinogen and  $^{125}\text{I}$ -fibrinogen followed, after a delay of two or so hours, by the appearance of  $^{125}\text{I}$ -labelled serum FDP. Some studies have been reported on the distribution and degradation of  $^{125}\text{I}$ -labelled fibrin injected into the circulation [131]. When  $^{125}\text{I}$ -fibrinogen free of thrombin and plasmin was clotted, the clot was separated, washed with ethanol, ground into a fine powder and injected into the circulation, this material, as judged by the appearance of non-TCA-precipitable  $^{125}\text{I}$ , was quite rapidly catabolized. When given intra-arterially, it was deposited in many organs; when given intravenously it was deposited primarily in the lungs and liver. The material was cleared from the blood in two minutes. It is not quite clear how closely such material represents fibrin naturally formed in the blood stream. After intravenous injection of thrombin in rats previously given  $^{125}\text{I}$ -fibrinogen, a similar organ distribution of  $^{125}\text{I}$ -fibrin was found [40]. If a large intravascular fibrin clot is formed, as in an aneurysm, the studies of Straub et al. [251] indicate that this mass of fibrin is in a continuous rapid turnover. Fibrin may also be deposited extravascularly. Extravascular fibrin is probably removed much more slowly than fibrin deposited intravascularly. Thus Kogler et al. [117] found that if  $^{125}\text{I}$ -human fibrinogen was injected subcutaneously just as it was about to clot, it was removed from the subcutaneous tissues of the volar human forearm, as determined by direct scanning, at a rate described by  $\alpha - \beta t$ , where  $\alpha$  is 100%,  $\beta$  is 0.49%, s.e. .04 and  $t$  is in hours. Thus, about one-half



the material is removed in four days. Mechanisms responsible for the subcutaneous removal have not been defined, but the form of the equation suggests a saturated enzyme system is responsible.

The above description primarily seems to apply to the path  $\theta_2$  in Figure 3. Formation of fibrin monomer in combination with fibrinogen and cold insoluble globulin, and so activation of the  $\theta_1$  path *in vitro*, requires treatment of fibrinogen with weak thrombin solutions [270]. Such products have been described as occurring in circulating plasma by Shainoff and Page [239] and Sherman [242]. They have been said to show a half life of 13 hours. *In vivo* fibrin monomer appears to be broken down into fibrinogen degradation rather than fibrin degradation products [137].

Thus if we examine the paths  $\theta_1$  and  $\theta_2$  in Figure 3, it is clear that we have a very inadequate understanding of the controls of the sizes of  $\theta_1$  and  $\theta_2$ . These must depend on the rate and amount of thrombin liberated, its inactivation by antithrombins, the levels of circulating antithrombins, particularly  $\alpha_2$ -macroglobulin and antithrombin III and, in some cases, on the level of heparin and fibrin(ogen) digestion products. We can only guess at the distribution of fibrin monomer and polymer in the interstitial fluids. We have no knowledge of the rate constants controlling the rate of exchange and breakdown of  $F_{1p}$  and  $F_{n_{p,e}}$ . We lump together tissue and blood fibrin polymer, though it is quite clear they behave differently. Finally, we are mainly ignorant of the breakdown compartments  $F_{n_b}$  and  $F_{1b}$ , though we may have some inklings of the progress in the release of fibrin digestion fragments such as D-D and E [137]. Clearly, at present we have a very imperfect idea of the metabolism and kinetics of \*I-fibrinogen, particularly by the paths  $\theta_1$  and  $\theta_2$  *in vivo*.

Plasminogen is activated by tissue activator, particularly rich in venous endothelia, by urokinase and by other activators to form plasmin [152]. Recently valuable studies have been made with \*I-plasminogen [53, 253, 259]. These have shown the appearance of \*I-plasmin on giving streptokinase, urokinase or typhoid vaccine and the prolonged release of plasmin after venous injury. The catabolic rate of plasmin appears to be about 1.2 plasma pools per day [253]. Released plasmin quite rapidly binds with circulating inhibitors [53]. Heparin and EACA inhibit release of plasmin by urokinase or venous injury, and plasminogen is not activated by the presence of blood clots [253]. Injections of plasmin into the circulation cause a rapid decline in plasma fibrinogen [53] and the appearance in the plasma of Fragments X, Y, D and E [137]. Of these, only Fragment X is clottable and Fragments Y, D, E must appear in the breakdown compartment  $fx_b$ . Again, if we examine our knowledge it is very incomplete. Thus we can hardly specify the mechanisms qualitatively, let alone quantitatively, that are responsible for the amount of circulating plasmin and so the size of  $\pi$ . We are completely ignorant of the size of the rate constants  $m_1$  and  $m_2$ . Fragment  $fx$  perhaps has a  $t_{1/2}$  of about 26 hours [242]. Clearly much more work needs to be done on the  $\pi$  and  $m$  pathways, their control and the size of their parameters.

Lastly, brief note may be taken of the two venoms. Arvin and Reptilase [19, 61, 249]. Both split off peptide A, which results in formation of loose fibrin clots. Both in small dosage lead to rapid removal of plasma fibrinogen without lowering of platelet count. Both cause the release of FDP but little systemic fibrin

deposition. Arvin causes a rapid fall of plasma \*I-fibrinogen, with prompt excretion of \*I into the urine. Neither venom causes embolism nor thrombosis. Antibodies may develop after repeated use [124]. Arvin, unlike thrombin, does not stimulate fibrinogen synthesis [19].

### PERTURBATIONS OF THE FIBRINOGEN SYSTEM IN DISEASE

The fibrinogen flow system diagrammed in Figure 1 provides a guide for classifying, interpreting and further studying abnormalities of fibrinogen metabolism. At present it is not always feasible to pinpoint each abnormality in a particular part of the flow system, but possibilities can be narrowed down, and experiments required to delineate the abnormality can often be formulated. In this section we discuss some of the problems in estimating critical flow parameters of the abnormal fibrinogen system, and then outline known or probable changes in these parameters which occur in disease.

#### Measurement of Flow Parameters Using Radioiodinated Fibrinogen

As noted above, when  $j_1$ ,  $j_2$  and  $j_3$  are constants, Equation 3 can be solved to yield

$$5) \quad *f_p = C_1 e^{-a_1 t} + C_2 e^{-a_2 t}$$

Fortunately, experimentally derived  $*f_p$  can be matched closely by Equation 5 in most of the pathologic states which have been studied [250, 254, 257, 258, 267, 268, 274]. The most notable exception to this experience is acute intravascular coagulation or fibrinolytic states occurring over a few hours, especially when accompanied by hemorrhage. Analysis of  $*f_p$  data by standard techniques gives numerical values for  $C_1$ ,  $a_1$ ,  $C_2$  and  $a_2$ , and these in turn provide numerical solutions for  $j_1$ ,  $j_2$  and  $j_3$ . As mentioned earlier, it is difficult in practice to measure  $j_1$  and  $j_2$  accurately. Their values are mainly dependent on  $*f_p$  data obtained during the first 48 hours of a radiofibrinogen study, and therefore may be seriously affected by the abnormally fast disappearance of even a small fraction of denatured labelled protein. In addition, in contrast to  $j_3$ , estimates of  $j_1$  and  $j_2$  are sensitive to small experimental errors in measured  $*f_p$  [46, 52, 197]. Clearly, studies in which  $j_1$  and  $j_2$  are important must be done with very carefully prepared radiofibrinogen, biologically screened when possible. Results must be based on mean values taken from a sufficiently large number of individual experiments.

Measurement of  $j_3$  is both easier and harder than measurement of  $j_1$  and  $j_2$ . This parameter, if only the core model is considered, is defined by

$$6) \quad j_3 = \left[ \frac{C_1}{a_1} + \frac{C_2}{a_2} \right]^{-1}$$

It is relatively insensitive to rapidly disappearing fractions of labelled protein and to experimental error in  $*f_p$ . However, if we include also the enzymatic pathways  $\theta_1$ ,  $\theta_2$  and  $\pi$  of Figure 1,

$$7) j_3 + \theta_1 + \theta_2 + \pi = J = \left[ \frac{C_1}{a_1} + \frac{C_2}{a_2} \right]^{-1}$$

where  $j_3$  represents the flow of plasma fibrinogen to normal catabolic sites and  $\theta_1$ ,  $\theta_2$  and  $\pi$  indicate the conversion of plasma fibrinogen to fibrin by thrombin or to fibrinogen degradation products by plasmin. In healthy men and animals, as noted above, we take  $\theta_1$ ,  $\theta_2$  and  $\pi$  to be zero or negligibly small. For practical purposes it would seem reasonable in both health and disease to include in the  $j_3$  outflow all of the normal mechanisms of irreversibly removing fibrinogen molecules from the plasma.  $\theta_2$ , the conversion of fibrinogen to Fn, fibrin polymer and  $\pi$  the lysis of fibrinogen by plasmin, would then represent abnormal pathways operating only in pathologic, therapeutic, or experimental situations.  $\theta_1$ , the conversion of fibrinogen to  $F_1$ , fibrin monomer might occur as part of the normal process of fibrinogen catabolism and thus be lumped with  $j_3$  or as the first step in the formation of polymerized fibrin and thus lumped with  $\theta_2$ . Equation 6a then reduces to

$$8) J = j_3 + \theta_2 + \pi = \left[ \frac{C_1}{a_1} + \frac{C_2}{a_2} \right]^{-1}$$

where  $j_3$ ,  $\theta_2$  and  $\pi$  are all constants.  $j_3$ ,  $\theta_2$  and  $\pi$  could be measured independently provided that at least two of the three secondary compartments,  $f_b$ , Fn and  $f_{x_p}$  could be sampled, but, with the possible exception of  $f_{x_p}$  (see below), this does not presently seem possible. On the other hand it may be reasonable to conclude that increases in J which are 1) not accompanied by consumption of platelets [86] or production of fibrin monomer [283], 2) not reduced by heparin, 3) not associated with retention of radioactivity in the body outside the plasma fibrinogen compartment [69], and 4) accompanied by the release of fibrinogen degradation products are probably due to an increase in  $\pi$  or  $j_3 + \pi$ , probably the former, since by definition no abnormal states are known in which  $j_3$  is increased. This solitary increase in  $\pi$  would encompass the syndrome of primary fibrinolysis.

Increases in  $\theta_2$  can be approached in a different way, but a powerful computer is required [69]. When significant amounts of radioiodinated fibrinogen are continuously converted to polymerized fibrin and then lysed via flow pathway  $\lambda_2$ , plasma radioactivity will decrease more rapidly than total body radioactivity because of retention of the label in compartment Fn [69, 70]. If  $*f_p$  in this pathologic setting can be defined by  $C_1 e^{-a_1 t} + C_2 e^{-a_2 t}$ , as is usually possible, and if radioiodide excretion is normal or else is measured independently [60, 68], solutions can be obtained for  $j_1$ ,  $j_2$  and J. The computer can then be programmed to generate a series of whole body radioactivity curves, using many different values for  $\theta_2$  and  $\lambda_2$  and to choose the  $\theta_2$ ,  $\lambda_2$  pair which gives the best fit to the measured whole body radioactivity data. With this procedure, J and  $\theta_2$  are measured, leaving  $\pi$  and  $j_3$  to be estimated. Since fibrin generation is nearly always accompanied by fibrinogenolysis,  $\pi \geq 0$ . By definition, however,  $j_3$  is unchanged, even though  $\theta_2$  and

$\pi$  are large. Thus the fraction of plasma fibrinogen continuously removed by the action of plasmin can be obtained from Equation 8,

$$\pi = J - \theta_2 - j_3,$$

where  $J$  and  $\theta_2$  are measured and  $j_3$  is the normal value for the catabolic rate for that species. For purposes of illustration, consider a rabbit with a large V2 carcinoma [69]. Fig. 4 shows that plasma \*I-fibrinogen,  $*f_p$ , declines at a markedly increased rate, while whole body radioactivity lags far behind. In normal animals, these two curves are parallel after 24-36 hours.  $J$  and  $\theta_2$  in this animal were measured as .84/day and .32/day, respectively. The normal value for  $j_3$  in animals of this age is .34/day. Therefore,

$$\pi = .84 - .32 - .34 = .18/\text{day}.$$

Within the limits of the method, we say that this animal was converting .32 of his  $f_p$  to fibrin and lysing .18 of his  $f_p$  to fibrinogen degradation products each day of the experiment. This method has also been applied to man [69, 70].

#### Alterations of Flow Parameters in Disease

We now examine each of the flow constants with special attention to alterations in disease states.

##### *Capillary Transfer Rate $j_1$ and Lymphatic Return Rate, $j_2$*

Very little is known about aberrations in this part of the fibrinogen system, probably because of the aforementioned difficulties in measuring  $j_1$  and  $j_2$ . Takeda [256] has reported a 25% decrease in  $j_1$  in patients with essential hypertension. He attributes this change to decreased capillary blood flow in the hypertensive patient. Early in the disease, the transcapillary flux  $j_1 f_p$  is also decreased, but as hypertension progresses, there is a rise in the fibrinogen concentration so that  $j_1 f_p$  again approaches normal. In contrast to fibrinogen, Rossing [231] found increased values in hypertension for both the fractional and the absolute transcapillary fluxes of albumin. A transient increase in  $j_1$  and  $j_1 f_p$  occurred in calves [252] and probably in rabbits [241] given endotoxin, presumably because of a temporary increase in capillary permeability and/or flow.

The ratio,  $f_e/f_p$ , which reflects the relative size of the intra- and extravascular pools is, in the steady state, equal to  $j_1/j_2$ .  $f_e/f_p$  in normal adult man is about .2 [255]. This ratio is not altered significantly in many diseases or clinical states in which  $f_p$  is increased [254, 257, 267]. It does, however, appear to decrease with age, at least in rabbits [10] and rats [170]. This decrease is due primarily to a fall in  $j_1$ .  $j_1$  in older rabbits was found to be about half that in younger rabbits [10].

##### *Catabolic Rate, $j_3$*

As noted above, virtually no pathologic conditions are known that alter  $j_3$ . It seems clear, however, that  $j_3$  decreases with age in rabbits [10] and rats [170]. This probably is true for man as well. In adult man,  $j_3$  is about .25 per day [255].

*Plasmin Rate of Fibrinogen Degradation,  $\pi$* 

Excessive plasmin-induced degradation of fibrinogen, flow pathway  $\pi$  (Fig. 1), is normally prevented by the action of the circulating inhibitors, particularly  $\alpha_2$ -macroglobulin and  $\alpha_1$ -antitrypsin [179]. Major increases in plasmin activity, which may be associated with a severe hemorrhagic diathesis, arise in a variety of clinical circumstances. These can be divided into secondary fibrino(geno)lysis, in which plasmin activation is the host's response to abnormal fibrin formation and primary fibrinogenolysis. Secondary fibrinolysis will be discussed below in connection with abnormal thrombin activity. Several reviews of the physiology and pathophysiology of the fibrinolytic enzyme system have been published recently [8, 124, 152, 226].

The common denominator of primary fibrinogenolysis is an excess of uninhibited plasminogen activator. The plasmin that is then released not only lyses fibrinogen but also can lower the plasma levels of Factors V, VIII and IX. The production of fibrinogen degradation products may contribute to a hemorrhagic process by inhibiting thrombin action [175] and by interfering with stable fibrin formation [100]. A syndrome typical of primary fibrinogenolysis may be seen when plasminogen activators like streptokinase or urokinase are used in the treatment of thromboembolic diseases [86, 267]. Primary fibrinogenolysis resulting in hemorrhage is much less common than bleeding associated with enhanced fibrin formation and secondary fibrinolysis, but it occurs in association with a variety of clinical disorders. These include postoperative states, especially following thoracic surgery, perhaps because tissues rich in plasminogen activator have been handled or damaged during surgery [151], and some cases of cirrhosis, because of impaired hepatic clearance of plasminogen activator [65]. A bibliography of the literature on clinical disorders in which hemorrhage due to primary fibrinogenolysis is thought to have occurred has been compiled by Ambrus et al. [5]. Such acute fibrinogenolytic states accompanied by bleeding may not be amenable to study with radioiodinated fibrinogen, both because of loss of the label from bleeding sites and because highly nonsteady state conditions prevent solution of the flow system differential equations. However, more chronic states of increased plasmin activity can be profitably examined. For example, Martinez et al. [139] have recently reported an unusual variant of giant hemangioma (Kasabach-Merritt syndrome). Their patient presented with decreased plasma fibrinogen, shortened euglobulin lysis time and increased fibrinogen-fibrin degradation products. Unlike other patients with the Kasabach-Merritt syndrome [251], this patient lacked features of intravascular coagulation such as thrombocytopenia and decreased Factor V and VIII levels.  $^{131}\text{I}$ -fibrinogen and  $^{125}\text{I}$ -prothrombin studies revealed a  $J$  of over twice normal for fibrinogen and a normal catabolic rate for prothrombin. Although whole body radioactivity data were not reported, which would have permitted calculation of  $\theta_2$  (the rate of fibrin polymer formation), the lack of increased consumption of prothrombin suggests that the increase in  $J$  in this case was due to an increase in  $\pi$  (plasmin degradation of fibrinogen) or what might be called "subacute primary fibrinogenolysis." Takeda and Chen [258] and Tytgat et al. [267] found an increase in  $J$  in patients with hemophilia A not found by some others [27, 89, 202]. They also found that the rate of whole body radioactivity loss equalled the rate of plasma radioactivity loss, indicating no significant contribution of  $\theta_2$  to the

increase in  $J$  in these patients. If  $j_3$  were not increased in hemophilia A we could conclude that an increased  $\pi$  was the cause of accelerated fibrinogen degradation in these patients. It is perhaps significant that epsilon aminocaproic acid, which inhibits plasmin activation, is reported to be useful as adjunct therapy in hemophilia A [176].

The experimental and mathematical procedures described in the first part of this section can provide presumptive measurements of  $\pi$  in subacute or chronic fibrino(genolytic) states. More precise definition of the plasmin pathway of fibrinogen breakdown could be obtained if  $f_{x_p}$  (plasma Fragment X) could be measured. Fragment X, which has a molecular weight of  $\sim 270,000$  and is clottable, is found in plasmin digests of fibrinogen, but not of crosslinked fibrin. Since Fragment X can be isolated by polyacrylamide gel electrophoresis [137], it might be possible to assay labelled X during a radioiodinated fibrinogen study, i.e., to sample compartment  $f_x$ . Care would have to be taken that the original labelled preparation contained no Fragment X. The resulting direct measurement of  $\pi$  might show, for instance, that chronic, low-grade fibrinogenolysis is much more common clinically than is now suspected. It might also allow quantification of what are claimed to be significant differences in fibrinolytic activity in supposedly healthy subjects. At present, most measurements of "fibrinolytic activity" are based on *in vitro* tests. Using such tests it has been reported that: women have greater fibrinolytic activity than men [43]; indigenous Africans have greater fibrinolytic activity than those of European origin [272], with higher plasminogen levels, and less depression of fibrinolysis after a fat meal [62]; decreased fibrinolytic activity is associated with obesity [181]; and increased activity with exercise [22, 43, 229] and perhaps physical fitness. However, it has been shown that there need be little or no correlation between *in vitro* measurements and *in vivo* studies with  $^{*1}$ -fibrinogen [96]. Clearly, carefully performed, more complete studies with  $^{*1}$ -fibrinogen might clarify some of these "normal" variations and might even identify populations at risk from thromboembolic disease.

#### *Rate of Fibrin Polymer Formation, $\theta_2$*

Thrombin-mediated conversion of plasma fibrinogen to fibrin occurs as a normal response to injury and pathologically in intravascular thrombosis and coagulation.

*Disseminated intravascular coagulation (DIC):* This has been the subject of several recent reviews [125, 149, 199, 245, 283] and will be discussed here primarily in the context of the fibrinogen flow system. In DIC the release or activation of procoagulants by the initiating disease process (infection, malignancy, abruptio placentae, etc.) results in activation of the coagulation cascade, consumption of factors, especially fibrinogen and Factors II, V, VIII and X and accelerated platelet consumption. Fibrin formation ensues, sometimes with deposition of fibrin in the microcirculation of kidney, brain, lungs and other organs [149]. Fibrin deposition produces ischemia and, less frequently, red blood cell damage with subsequent hemolysis. The characteristically distorted and fragmented red cells apparently result from passage through fibrin strands in the microcirculation [39, 235]. An important consequence of fibrin formation is the release of plasminogen activator from the vascular endothelium. Plasmin formed by this secondary

activation of the fibrinolytic system acts at seven sites diagrammed in Figure 1:  $\pi$ ,  $\lambda_1$ ,  $\lambda_{1a}$ ,  $\lambda_2$ ,  $\lambda_3$ ,  $\kappa_1$  and  $\kappa_2$ . Fibrinolysis, including thrombolysis, occurs via flow parameter  $\lambda_2$ , with the subsequent release of Fragment D dimers and Fragment E [137]. This process is so efficient that, despite a high rate of fibrin formation, it is often difficult to find even small thrombi in the vessels of patients who have died with DIC. Excess plasmin production also results in fibrinogenolysis along pathway  $\pi$ , with release of Fragment X, which circulates in compartments  $fx_p$  and  $fx_e$ . Fragment X is further lysed along pathway  $\lambda_3$  to Fragments Y, D and E. In addition, fibrin monomer in compartments  $F_{1,p}$  and  $F_{1,e}$  is lysed via pathways  $\lambda_{1a}$  and  $\lambda_1$  to Fragments X, Y, D and E. These fragments, especially X and Y, have a direct antithrombin effect and also inhibit fibrin polymerization [100]. Finally, Fragments Y, D, and E are further degraded by enzymatic action, at least partially due to plasmin, to peptides and amino acids along pathways  $\kappa_1$  and  $\kappa_2$ . Some of these smaller intermediate products of fibrin digestion have platelet inhibiting activity [121].

The list of clinical conditions which may be complicated by DIC is continually growing. They may be classified, with considerable overlap, according to their proposed causation [125, 149, 245]. Causative factors are thought to include 1) release of red cell procoagulants—as in malaria, incompatible transfusion, hemolysis during extracorporeal circulation, and massive hemolysis from other causes; 2) release of tissue procoagulants—as in abruptio placentae, amniotic fluid embolism, eclampsia, retained dead fetus, disseminated malignancy, including acute leukemia, burns; 3) damage to endothelial cells—as from heat stroke, hypothermia, endotoxin release, rickettsial and viral infections; 4) release of other procoagulants, promoted by bacteria, especially gram negative microorganisms, viral hemorrhagic fevers, pancreatitis, snake venom, fat embolism, hyperlipemia; and 5) vascular stasis, as from shock, pulmonary embolism, congenital heart disease, giant hemangiomas. This list is incomplete but gives some idea of the diversity of abnormalities which can give rise to DIC.

Many of the entities mentioned above lead to an acute fulminating episode of intravascular coagulation, which may last only a few hours and terminate spontaneously, or as a result of successful treatment, or with the demise of the patient. Heparin is the mainstay of treatment, though Arvin and Reptilase, whose action is described above, hold promise [125]. When fibrinolytic activity is excessive, epsilon aminocaproic acid (EACA) can be added to the therapeutic regimen but its use is hazardous, except when specifically indicated and in a well heparinized patient.

Subacute and chronic forms of intravascular coagulation, lasting days to weeks or even longer, are becoming increasingly well recognized, both as pathologic entities and as contributors to the pathophysiology of the associated disease. Classification of intravascular coagulation into acute, subacute and chronic forms is arbitrary since the spectrum is probably continuous from acute to very low grade chronic disorders [54].

*Subacute and chronic intravascular coagulation:* Chronic intravascular coagulation differs from the acute form in several important respects. As in acute DIC, the coagulation system is activated, fibrin is formed and secondary fibrinolysis develops. However coagulation does not proceed at a rate rapid enough to deplete

the blood of clotting factors and platelets; instead there may be a paradoxical rise in their levels, presumably because of an increased synthetic stimulus. Ongoing fibrinolysis ( $\lambda_1$ ,  $\lambda_{1a}$  and  $\lambda_2$ ) is part of the syndrome, but significant fibrinogenolysis ( $\pi$ ) may not be. Chronic intravascular coagulation may be disseminated or localized. The latter term is used for conditions in which fibrin production and lysis occur primarily in one organ or tissue as in cirrhosis, giant hemangioma or malignant tumors. Localized intravascular coagulation may also be acute [149], but in the following discussion we are concerned primarily with chronic and subacute coagulation. Subacute intravascular coagulation, either disseminated or localized, usually does not last as long as chronic intravascular coagulation, but more importantly, is characterized by a faster rate of consumption so that clotting factors are decreased below normal in the blood. The relative steady state and expanded time frame of chronic intravascular coagulation and of subacute intravascular coagulation permit useful clinical studies with radioiodinated proteins to be accomplished, particularly with the use of the analytical techniques described in the first part of this section. In addition, radioisotopic scanning may provide important additional information about the location and kinetic behavior of the coagulative/fibrinolytic process. Some important distinguishing features of radioiodinated fibrinogen metabolism in subacute and chronic intravascular coagulation are: 1) an increased  $J$ , calculated from Equation 8; 2) a divergence between the whole body radioactivity curve (defined by the sum of radioactivities in all compartments of Figure 1 excluding  $*u$ ) and the plasma radioactivity curve  $*f_p$ ; the former is slower, the latter is faster than normal; 3) reduced retention of whole body radioactivity (in  $*F_n$ ) when anticoagulant or fibrinolytic drugs are given, resulting in less divergency of the plasma fibrinogen and whole body radioactivity curves; and 4) reversion of  $J$  toward normal when anticoagulant drugs are given because of interference with pathway  $\theta_2$ . In addition, in patients with localized intravascular coagulation, uptake of radioactivity in the local site, that is in compartment  $*F_n$ , is reduced by pretreatment with heparin, as determined by external radioisotopic scanning.

Not all these criteria have been met in the examples that follow, mostly because of lack of published data.

*Cancer:* Although acute DIC may develop in patients with malignancy, especially disseminated malignancy, chronic, localized coagulation and fibrinolysis may be much more common. The presence of fibrin deposits in human [99] and animal tumors [182-184] has been reported, as has localization of radioactivity after administration of radioiodinated fibrinogen and antifibrin [59, 219, 247]. It has been postulated that a specific procoagulant is responsible for tumor deposition of fibrin and that fibrin serves as a matrix for tumor growth [31, 32, 186, 187]. Proof that fibrin deposition and removal is a dynamic, ongoing phenomenon in tumors rests with kinetic studies using radioiodinated fibrinogen. Figure 4 shows how retention of radioactivity in  $F_n$  causes a discrepancy in the rates of decline of whole body and plasma radioactivity curves in a tumor-bearing rabbit. These animals also show clearcut localization of radioactivity over the tumor when radioisotopic scanning is done. In experiments continued for a longer period, it can be shown that, as  $*f_p$  declines  $\lambda_2 *F_n$ , flow of radioactivity out of  $*F_n$ , exceeds  $\theta_2 *F_n$ , flow of radioactivity into  $*F_n$ . Then  $*F_n$  begins to decline [69, 162] and,



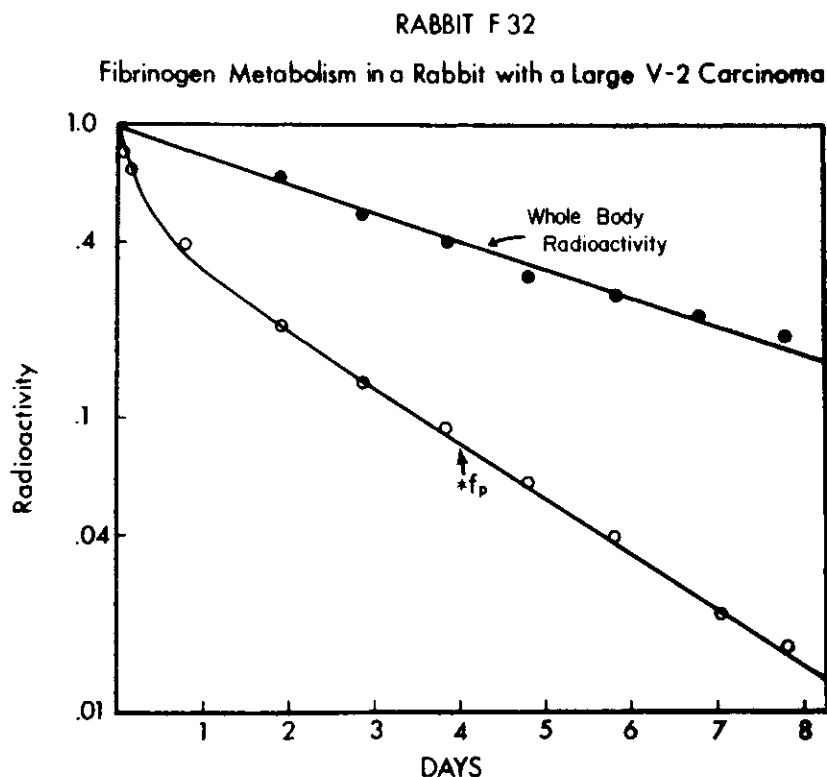

FIG. 4: Disappearance of plasma  $^{125}\text{I}$ -fibrinogen,  $*f_p$ , and whole body radioactivity following injection of  $^{125}\text{I}$ -fibrinogen at zero time intravenously. Following injection of tumor fragments, the rabbit had grown a large V-2 carcinoma in the thigh.

concomitantly, the whole body and plasma radioactivity curves approach parallelism. Patients with cancer show the same alterations in fibrinogen metabolism as seen in cancerous rabbits. Fourteen patients with large carcinomas had an average  $J$  of .31/day, 25% greater than normal, with divergent plasma and whole body radioactivity curves.  $^{125}\text{I}$ -fibrinogen metabolism reverted toward normal with continuous heparin infusion [69, 70].

Straub [250] recently reported the results of  $^{131}\text{I}$ -fibrinogen studies in 33 patients, including normal subjects, patients with subacute intravascular coagulation, (hypofibrinogenemia, thrombocytopenia, reduced levels of Factors II, V, and VIII) and patients with "suspected" intravascular coagulation. Among these patients were five with carcinoma. Straub's values for the "fractional breakdown rate" and "fibrin pool size" are difficult to interpret, since his calculations are apparently based on the assumption that the fibrin compartment exchanges only with the extravascular compartment. However, he provides graphical data for several patients, including one with carcinoma, which show the discrepancy between whole body and plasma fibrinogen radioactivity curves characteristic of intravascular coagulation.

Some of the earliest kinetic studies of radiofibrinogen metabolism in malignant states came from the group at Pisa [162, 163, 220, 221, 222]. These investigators, utilizing external counting over tumorous and nontumorous areas, showed enhanced uptake and retarded decline in radioactivity in tumors compared with nontumorous areas. Heparin therapy resulted in reversion of the tumor radioactivity curve to a more normal configuration.

More recently Harker and Slichter [86] reported labeled platelet and fibrinogen studies in 104 patients with various diseases. In thirteen patients with cancer they found an average threefold increase in platelet and fibrinogen consumption.

The possibility that localized coagulation may play a role in the growth and spread of tumors is intriguing. Several recent papers lend further support to the idea that anticoagulants and fibrinolytic agents might be useful adjuncts in the treatment of cancer [154, 155, 263, 264, 285].

*Hepatic cirrhosis:* Tytgat et al. [268] studied radioiodinated fibrinogen metabolism in 50 patients with cirrhosis of the liver. They found that  $J$ , calculated from  $[C_1/a_1 + C_2/a_2]^{-1}$ , averaged .34/day in their cirrhotics, compared with .24/day in 35 healthy control subjects,  $p < .001$ . They did not publish whole body radioactivity data. Heparin anticoagulation resulted in prolongation of fibrinogen half-life by one day or more in eight out of ten patients and in an increase in fibrinogen concentration in six out of ten patients. Antifibrinolytic therapy with tranexamic acid resulted in prolongation of fibrinogen half-life by one day or more in three of 17 patients. No rise in plasma fibrinogen was observed. Fibrinolytic therapy in one of the 17 patients so treated was associated with thrombotic occlusion of the right ileofemoral artery. From these data it appears that subacute or chronic intravascular coagulation is a relatively common feature of hepatic cirrhosis. An increased  $J$ , which can be reduced by heparin therapy, suggests that  $\theta_2$  is the abnormal flow pathway. However, reduction of  $J$  by an antifibrinolytic agent in a few patients suggests that increased fibrinogenolysis along pathway  $\pi$  can occur in some cirrhotic patients, as noted above. Separation of these two mechanisms can be achieved by the use of accurate whole body radioactivity data.

Tytgat et al. [266] demonstrated that accelerated fibrinogen consumption was due to hepatocellular damage rather than portal hypertension. Dogs with carbon tetrachloride-induced chronic liver damage had increased  $J$ 's which could be reverted toward normal with heparin therapy. In contrast, dogs with occluded portal veins had normal plasma loss rates of fibrinogen.

Rats with carbon tetrachloride-induced hepatic necrosis were studied by Rake et al. [200]. Removal of labelled fibrinogen from the plasma was more rapid in carbon tetrachloride-treated animals than in controls. Heparin reduced the removal rate, while the antifibrinolytic drug tranexamic acid increased the rate slightly. Excessive deposition of the label occurred in the livers and, to a lesser extent, in the spleens of the animals with hepatic necrosis. Heparin retarded the appearance of hepatic necrosis, while tranexamic acid influenced the course adversely, thus emphasizing the protective effect of fibrinolysis in intravascular coagulation.

*Leukemia:* Reeve et al. [210] reported a patient with acute stem cell leukemia who developed large ecchymoses. She had a markedly shortened euglobulin lysis time.  $^{131}\text{I}$ -fibrinogen study showed a  $J$  of 1.6/day, over six times normal, and parallel plasma and whole body radioactivity curves, suggesting predominant

fibrinogenolysis. Gralnick et al. [77] found increased  $^{51}\text{Cr}$ -fibrinogen plasma loss in three patients with acute leukemia, as did Straub [250] in a patient with acute promyelocytic leukemia. The series of Gralnick et al. also included twelve patients with hypofibrinogenemia, decreased Factor V and decreased platelets, and elevated fibrin-fibrinogen degradation products. Seven of these patients developed bleeding, which did not respond to platelet transfusion, but which did respond to heparin therapy. More studies are needed but it seems likely that bleeding in leukemic patients can be due to either primary fibrinogenolysis or intravascular coagulation and secondary fibrino(genol)ysis. Leukocytes probably contain plasminogen activator [109] as well as thromboplastic substances [174].

*Thrombocytosis:* Tytgat et al. [267] studied  $^{51}\text{Cr}$ -fibrinogen metabolism in seven patients with primary thrombocythemia and one with postsplenectomy thrombocytosis.  $J$  averaged .31/day, significantly greater than normal. Heparin administered to one patient and the antifibrinolytic agent tranexamic acid to four resulted in prolongation of the fibrinogen half-life. Martinez et al. [138] gave  $^{125}\text{I}$ -prothrombin and  $^{131}\text{I}$ -fibrinogen to ten patients with thrombocytosis: six with primary thrombocythemia, one with myeloid metaplasia, and three with polycythemia vera. Mean values for the fractional catabolic rates ( $J$ 's) of both proteins were increased to nearly 50% above normal. Therapeutic reduction of platelets to the normal range, presumably with cytotoxic agents, was associated with normalization of the catabolic rate.

*Polycythemia:* Six patients with primary or secondary polycythemia were included in the report of Tytgat et al. [267].  $J$  was significantly increased (mean  $.33 \pm .06$ ). Heparin, which was given to three patients, resulted in prolongation of the fibrinogen half-life.

*Injury:* Davies et al. [56] gave  $^{131}\text{I}$ -fibrinogen to eight young patients mostly with knee injuries, and to eight elderly patients, mostly with fractures of the femur. All patients were studied after reparative surgery, and four young patients were studied before and after surgery. In these patients, plasma radioactivity disappeared more rapidly, and whole body radioactivity more slowly, than normal. The discrepancy between whole body and plasma radioactivity loss rates was more marked in elderly patients. The authors conclude that sequestration of fibrinogen, perhaps as fibrin, probably accounted for retention of radioactivity outside the plasma compartment. Harker and Slichter [86] found decreased survival of both blood platelets and fibrinogen in ten surgically traumatized patients.

*Bacteremia:* In 1967 Rubenberg et al. [234] reported radiofibrinogen studies in a patient with *Clostridium perfringens* septicemia, massive hemolysis and markedly depressed clotting factors.  $J$  was measured, as .47/day, about twice normal. Improvement followed exchange transfusion, heparin therapy and fibrinogen infusion. Two weeks later  $J$  was measured as .27/day, nearly normal. Harker and Slichter's five patients with bacteremia [86] had fibrinogen and platelet "survival times" that were reduced to nearly a fifth of normal. Three patients with bacterial endocarditis [276] also had increased radiofibrinogen loss rates. In another study, Wardle [275] gave labelled fibrinogen to six patients with septicemia. All were found to have markedly shortened fibrinogen half-lives. Whole body radioactivity data could provide useful additional information in future studies of patients with bacteremia.

*Renal Disease:* Certain types of renal disease may be associated with chronic intravascular coagulation, which may also play a role in their pathogenesis [274]. Interest in fibrinogen metabolism in renal disease followed from the finding of fibrin deposits in glomeruli in rapidly progressive glomerulonephritis, malignant hypertension, hemolytic uremic syndrome, eclampsia and transplant rejection. The dramatic response to heparin, phenindione and dipyridamole of five patients with acute progressive glomerular nephritis [115], a heretofore universally fatal disease, was particularly indicative of a pathogenic role for fibrin deposition. The urinary excretion of fibrin-fibrinogen degradation products (FDP) in renal disease, particularly proliferative glomerulonephritis [90, 91, 171] and lupus glomerulonephritis [34] is of further interest. The lack of correlation between the concentration of FDP in the serum and urine [92] argues against urinary FDP arising from filtration of plasma FDP through damaged glomeruli. Wardle, in a recent review [274], reported accelerated loss of plasma radiofibrinogen in patients with acute renal failure, terminal uremia, malignant hypertension with vascular damage, chronic nephritis with hypertension, rapidly progressive glomerulonephritis and immune complex nephritis. Data regarding whole body radioactivity were not included in his report. Straub's data [250] from a patient with acute glomerulonephritis and from another with "chronic renal transplant rejection" show the pattern of accelerated plasma radioactivity loss, associated with retarded excretion of the label, that is characteristic of chronic intravascular coagulation (assuming, of course, that radioiodide excretion is not impaired). The analytical data of both these authors are difficult to interpret since they use the method of Pearson et al. [191] to calculate the fractional catabolic rate and the mass ratio of intravascular to extravascular fibrinogen. This technique does not apply if significant radioactivity is retained in compartment F<sub>n</sub> (Fig. 1). It is valid only if retained fibrin is in a compartment more remote from the plasma compartment, that is, in exchange only with  $f_e$ , the fibrinogen extravascular compartment. One argument against such an arrangement is that  $*f_p$  would be defined, under these circumstances, as the sum of three exponential terms. This is not in keeping with observed data from many sources, including Straub and Wardle.

One interesting observation is that many patients with renal disease excrete more X and Y fragments than the smaller D and E fragments [91]. The X and Y fragments may result from the renal breakdown of fibrinogen [137]. However, urokinase levels are decreased in the urine of such patients [91]. An alternate explanation is that most of the fibrin deposited and lysed in diseased kidneys is noncrosslinked [137]. In terms of Figure 1, this would represent conversion of fibrinogen along pathway  $\theta_1$ , rather than to Fragment X along pathway  $\theta_2$  to F<sub>n</sub> and Fragments D-D and E.

From this very partial list, it can be seen that intravascular coagulation, manifested by deranged radiofibrinogen metabolism, occurs in a wide variety of clinical syndromes. The rate of the abnormal process varies from very rapid to barely detectable. More interesting than the response of the coagulation system to those many clinical states is the possibility that fibrin formation may play a role in the pathogenesis of some diseases. This possibility seems most likely in neoplastic and renal disease.

*Venous Thrombosis:* Venous thrombosis is not properly included in the syndrome of intravascular coagulation, but clots in the large veins of the body also

result from activity of thrombin along pathway  $\theta_2$ . Moreover, fibrinolysis is an important protective response, and deposition and removal of fibrin in or around the clot is a dynamic process which probably alters radiofibrinogen metabolism in much the same way as does localized intravascular coagulation. Localization of radioactivity in venous thrombi after administration of labelled fibrinogen, first demonstrated by Hobbs and Davies [102], has become an important diagnostic tool [16, 64, 113, 172, 173, 189]. The use of  $^{125}\text{I}$ -fibrinogen in the diagnosis of venous thrombosis has been reviewed recently by Kakkar [114], Browse [36], and Warlow [277]. Jeyasingh et al. [110] found an increased rate of loss of plasma radioactivity in patients with thrombosis, but this observation was not confirmed in reports by Hickman [95] and Simmons [244]. However, van der Mass and coworkers [269] found not only a shortened half-life for labelled fibrinogen in patients with venous thrombosis, but also that half-lives reverted to normal with anticoagulant therapy. They concluded that measurement of the plasma disappearance rate of labelled fibrinogen was more sensitive than external scintillation counting. Harker and Slichter [86] found a significant reduction in both fibrinogen and platelet survival, corrected by heparin, in patients with venous thrombosis. Dipyridamate was not effective.

#### *Relation of Fluxes to Rate Parameters*

In the foregoing discussion we have primarily been concerned with alterations of the rate parameters in disease (Fig. 1). For the most part we have omitted a discussion of the corresponding fibrinogen fluxes or mass transfer rates, e.g.  $\pi f_p$  and  $\theta_2 f_p$ . These will be discussed after the next section dealing with fibrinogen synthesis.

### FIBRINOGEN SYNTHESIS AND SECRETION

In this section we are interested first in what is known of the molecular and cellular biology of fibrinogen synthesis so that we may better understand the regulation of fibrinogen synthesis and secretion in the living animal. We are then interested in studies directly measuring fibrinogen secretion made during organ perfusions or in the living animal and the problems associated with such studies. Because of the paucity of both kinds of studies, we shall be forced to draw on knowledge obtained in studies of other liver synthesized proteins, particularly albumin and of mammalian protein synthesis in other tissues.

It is perhaps unnecessary to note that the rate of fibrinogen synthesis is that rate at which the complete fibrinogen molecule is formed in the hepatocyte, while the rate of fibrinogen secretion is that rate at which fibrinogen leaves the liver cell to enter the circulation. Except for brief periods during change in synthetic rate, these two must always be equal, unless an active catabolism of unsecreted fibrinogen in the liver cell takes place. Considering its relatively easy identification under the electron microscope [82], its relatively easy measurement in extra- and intracellular fluids [127], its synthesis from three defined peptides [169] and the addition to it of carbohydrate [169]; considering also that now techniques are available for fractionating the cell protein synthesizing apparatus [35] and are being developed for isolating mRNA [35]; and considering, finally, the importance

of fibrinogen in disease—it seems that studies of the molecular mechanisms of fibrinogen synthesis should be of great basic interest and practical importance. The paucity of such studies so far, and in fact the paucity in general of studies of fibrinogen synthesis and its regulation, is therefore surprising. We may, however, note that promising developments are now being made in tissue culture of liver cells which synthesize fibrinogen [23, 112, 198] and these may pave the way for such studies.

### Sites of Fibrinogen Synthesis

Almost all fibrinogen is synthesized in the liver [156], but possibly a very small amount is synthesized in the platelets [210]. In the rat, 65% of the number of liver cells making up 90% of liver cell mass are hepatocytes and the rest are reticulo-endothelial Kupffer cells [55]. In dogs, 81% of the number of liver cells are hepatocytes and in man, 71% [18]. By fluorescent antifibrinogen antibody staining in health, most hepatocytes stain weakly for fibrinogen [18]. Other investigators find about 1% of hepatocytes stain strongly for fibrinogen [84]. A strong stimulus to fibrinogen synthesis leads in a few hours to strong staining of most hepatocytes by fluorescent antibody [18].

### Cellular Biology of Albumin and Fibrinogen Synthesis

Fibrinogen is continually synthesized and secreted by the liver, though there may be quite rapid fluctuations in synthetic rate [13]. Our knowledge of the secretion of liver export proteins is small and is primarily derived from studies of albumin [232]. Many confirmatory studies are required to demonstrate that these findings are also true for fibrinogen, but it seems likely that there will be close similarities. Albumin is synthesized on the polysomes of the rough endoplasmic reticulum within the endoplasmic reticulum (ER) canals [195], passes down into the smooth ER canals, enters the Golgi apparatus [195, 196] and probably is then extruded through vesicles in the cell membrane into the sinusoids. In the pancreatic cell, where amylase secretion follows similar paths, amylase is finally packaged in the Golgi apparatus by condensation into zymogen granules, which act as temporary stores and then, after fusion with the cell membrane, release their contents into pancreatic ductules [42, 107, 108]. There is no evidence of zymogen granules for export proteins in the liver. Albumin is formed from a single polypeptide chain [194], fibrinogen from pairs of three separate chains: the  $A\alpha$ ,  $B\beta$  and  $\gamma$  chains [169]. These must be linked together, but we do not know the mechanisms involved nor where in the endoplasmic reticulum this occurs. During passage through the ER canals, carbohydrate must be added [168]. Synthesis of albumin on the polysomes of the rough endoplasmic reticulum is very rapid, taking a minute or so [195], whereas passage through the ER canals to the blood stream takes 15 minutes or longer [195]. Intracellular hepatocyte albumin can be fractionated into that bound to the rough endoplasmic reticulum (RER), that bound to the smooth endoplasmic reticulum and that in the Golgi apparatus [196]. After injection of  $^{14}C$ -leucine maximum radioactivity in the RER of rat liver is

achieved in approximately 5 minutes, in the smooth microsomes in about 15 minutes and in the Golgi apparatus in about 20 minutes [196]. Passage times of albumin through the rabbit liver cell average 36 minutes [207], and of hepatocyte fibrinogen, about 45 minutes [129]. From these, total quantities of the two proteins in the 60 gm liver of a 2 kg rabbit can be estimated as approximately 18 mg albumin and 4 mg fibrinogen, respectively. Agreement is quite good with direct measurements of liver albumin [76, 195].

The levels of liver albumin [166] and of fibrinogen [18] rise and fall with the rate of synthesis of these proteins, suggesting passive transfer of protein through the canals of the endoplasmic reticulum, perhaps by fluid flow. However, the level of a liver intracellular protein as measured by fluorescent assay is not always a good estimator of its rate of secretion [284]. In healthy man, albumin accounts for 50% of total liver protein synthesis and fibrinogen for 10% [232]. In disease, fibrinogen synthesis may briefly increase 10- to 20-fold and then dominates liver protein synthesis [13, 14, 210].

#### **Possible Molecular Mechanisms Regulating Rates of Fibrinogen Synthesis**

In the absence of experimental knowledge of the molecular biology of fibrinogen synthesis, we very briefly summarize current knowledge of the mechanisms that in general control protein synthesis in the eukaryote. Excellent reviews are given by Wainwright [271], Hoagland [101], Munro [168] and others [35]. Work on bacterial cells has tended to confirm and elaborate the proposals of Jacob and Monod [106]. Work on eukaryote cells and, particularly, mammalian cells, has been very sparse in comparison but seems to show that features of the Jacob-Monod scheme also apply to several proteins synthesized by mammalian cells. However, the controls of protein synthetic mechanisms in the mammalian cell are much more complex than in the bacterial cell. One important difference between the two, apart from the mere difference in cell volume, which immediately superimposes great differences in physical parameters, such as the time taken for diffusion through the cell, the surface to volume relationships and so on [98], is that the natural behavior of the bacterial cell is growth, rapid reproduction and rapid protein turnover, while the natural behavior of many mammalian cells in the adult living animal is a near steady state of total cell mass with only slow death and replacement of cells. Thus replacement of liver cells is calculated to be about 0.1% per day [1]. In spite of these differences, however, a number of the intracellular proteins in the hepatocyte cell are formed and broken down nearly as fast as those in *E. coli* [237]. Thus the half-life of ornithine decarboxylase in the rat liver is 11 minutes [237]. Table 2 summarizes current thought on the mechanisms regulating the rate of eukaryote mRNA transcription and entry into the cytoplasm and on those regulating the rate of translation of this mRNA into protein synthesis. Table 2 is sufficiently complete not to require further elaboration. One difference between the bacterial cell and the mammalian cell as noted below seems to be in the importance of translation rather than transcription mechanisms for regulating protein synthesis [168].

TABLE 2. Some Transcription and Translation Mechanisms Probably Active in Fibrinogen ( $\phi$ ) Synthesis

	Chromatin aggregates containing multiple copies of some genes
	DNA-dependent RNA polymerases—some specificity possible in types of mRNA formed
<i>Transcription Control</i> (Nucleus)	Formation of high MW complementary RNA (cRNA) in rapid turnover
Factors affecting rate of $\phi$ production	Messenger RNA release from cRNA mRNA-protein complex formation Intranuclear breakdown mRNA Stimulation of mRNA formation by some but not other hormones Repression (coarse control) by histones and acid phosphoproteins Passage of mRNA-protein to cytoplasm
<i>Translational Control</i> (Cytoplasm)	$\phi$ -mRNA cytoplasmic entry and catabolic rate
Factors affecting rates of $\phi$ formation and release from RER* templates	Ribosomes: subunits and numbers Ribosome assembly into polysomes and affinity for $\phi$ -mRNA Initiation, elongation and release factors Aminopeptidases Available transfer RNAs dependent on aminoacyl r-RNA synthetases Available amino acids, ATP, Mg, etc.

\*Rough endoplasmic reticulum.

## PHYSIOLOGIC AND PATHOPHYSIOLOGIC STUDIES OF ALBUMIN AND FIBRINOGEN SYNTHESIS

### *Liver Perfusion*

Though there have been few studies with cell particulates of synthesis of albumin or fibrinogen, liver perfusion studies have yielded some valuable information. Liver perfusion was first developed by Miller and Bale [156] and Miller and associates [157]. The liver is rapidly removed from a donor animal and is perfused from a reservoir containing blood from the same or a different species or a suspension of red cells in serum [111] or in a plasma substitute [159]. The blood is kept oxygenated by bubbling a mixture of oxygen and carbon dioxide through it [159]. The bile duct is cannulated and the rate of bile secretion is measured [159]. The advantages of the method are that the input of nutrients to the liver can be exactly controlled, the liver is free from extrahepatic regulations exercised by other body tissues and the rate of output of materials secreted into the artificial blood stream is easily determined. The disadvantage is in the difficulty of being certain, in any given experiment, of how normal is the function of the perfused liver. Currently used indicators of normal function are rate of bile secretion, rate of urea production, rate of synthesis of one or more plasma proteins, perfusing blood lactate/



pyruvate ratio, level of liver glycogen and rate of glucose secretion [284]. Different investigators use perfusion periods of two or three hours [232], up to six hours [261] and up to 12 or even 24 hours [160]. Even the longer periods give insufficient time for testing some of the slower liver responses, for instance responses characterized by altered secretion rates of proteins. For studies of the latter kind, the donor animal is exposed to different sets of experimental conditions and it is hoped that the perfused liver obtained from this animal will continue to reflect the state present in the living donor animal. A problem that may have particular relevance to the study of rate of protein secretion by the perfused liver is that several investigators perfuse with mixtures of red cells obtained from the same species, but with serum obtained from another species [111]. This allows direct measurements by immune methods of the levels of protein secreted by the liver without interference by proteins already present in the perfusing blood. However, altered clotting proteins and their products in serum may provide strong stimuli to increase the secretion rate of fibrinogen and other acute phase proteins [18, 30], while species differences in serum constituents might also lead to alterations of protein synthetic rate.

#### *Mechanism Regulating Albumin Synthesis Revealed by Liver Perfusion Experiments*

Relevant findings need only very brief summary. In a number of situations, e.g. poor nutritional state and perfusion of the isolated liver with 0.2% alcohol or 0.25% carbon tetrachloride, the liver secretes albumin at much reduced rates [232]. Polysomes extracted from the liver then show abnormal disaggregation, though it is not always clear if these *in vitro* studies reflect the state of liver polysomes [135] *in vivo*. Several stimuli that increase albumin synthetic rate, e.g., thyroid hormone and cortisone, seem to increase the numbers of membrane-bound ribosomes [232]. Thus regulation of the rate of liver albumin synthesis seems to be by translation mechanisms [168].

#### *Studies of Fibrinogen Synthesis in the Perfused Liver*

For these studies Miller and associates used the rat liver. This was either perfused with rabbit erythrocytes in rabbit serum diluted with Ringers solution (RE-RS) [111] or perfused with bovine erythrocytes suspended in bovine albumin-Ringers solution (BE-BA) [161]. Perfusions with the former (RE-RS) lasted six hours, with the latter (BE-BA) lasted 12 or even 24 hours [160]. Also, in the latter experiments, donor rats were specially selected to avoid diseased animals (L. L. Miller, personal communication). With RE-RS perfusion, fibrinogen synthesis averaged approximately 0.6 mg per Gm liver per hour [111], with BE-BA perfusion (by our calculations) approximately 0.1 mg per Gm liver per hour [160]. Thus the avoidance of heterologous serum and the choice of healthy liver donor rats free from acute phase responses resulted in a much reduced rate of secretion of fibrinogen. Using the latter results, the 10 Gm liver of a 200 Gm rat would secrete 24 mg fibrinogen per day, as compared with a measured synthesis rate *in vivo* of 13 to 20 mg/day [236], depending on plasma fibrinogen concentration. Using RE-RA perfusion medium with results perhaps therefore open to some question, injection of

thrombin into donor rats before sacrifice led to marked increases in fibrinogen secretion rate by their isolated livers [161]. Using the BE-BA perfusion medium, "full supplementation" by addition to the perfusion medium of a complete amino acid mixture and large doses of one or more of the hormones cortisol, insulin and growth hormone, led to increased fibrinogen secretion during the second six hours of a 12-hour infusion, as compared with controls. Studies with actinomycin D suggested to the investigators that the mRNA for rat fibrinogen had a half-life of 1.5-2 hours [111]. As compared with controls neither induction of hypo- nor hyperthyroidism in the donor rats nor infusion of thyroxine into the BE-BA perfusion medium had a significant effect on fibrinogen secretion rate by the perfused liver [80]. The livers of hypophysectomized animals perfused with BE-BA medium averaged about one-third the fibrinogen secretion rate of livers from normal animals. "Full supplementation" with amino acids infused during the liver perfusion with large doses of cortisol, bovine growth hormone, insulin and tri-iodo-thyronine seemed to restore liver fibrinogen secretion in the hypophysectomized animal to normal levels [79]. In other studies [158], omission of tryptophan or threonine from the perfused amino acid mixture was without effect on fibrinogen secretion rate. An 18-hour fast of the donor was also without effect, though a six-day fast led to a marked reduction. Twelve-hour infusion of ACTH in high dosage was without effect on fibrinogen synthesis in the perfused liver [160]. Miller and Griffin have recently reviewed many of these studies [160].

In assessing liver perfusion studies, the following remarks may be pertinent. The whole animal presents an extraordinarily complicated metabolic system regulated by innumerable hormonal and other feedback loops. To avoid these feedback effects and to try to obtain further understanding of mechanisms in their absence, studies of organs, tissue slices, cell fractions and so on are essential. But these portions of animals in the absence of their normal feedback regulations may present bizarre behavior. Because of this, it would be expected that studies of many workers over a number of years would be required to relate satisfactorily the very complex behavior of the isolated perfused liver to that of the highly regulated liver in the living animal. It is our present feeling that the behavior of the isolated perfused liver is still not sufficiently well defined to allow studies made with this preparation to be safely equated to the behavior of the liver *in situ*. However, we are certain that continuing study of this preparation will, in the future, throw much light on the behavior of the liver in the living animal.

### Studies of Fibrinogen Synthesis and Secretion In Vivo

#### *Methods for Direct Measurement of Fibrinogen Secretion Rate*

*The arginine-6-<sup>14</sup>C method:* The basis of the first satisfactory method of measuring synthetic rate *in vivo* of a liver-synthesized plasma protein was described by Reeve, Pearson and Martz in 1963 [208]. Since then, various forms of the method have been used in humans [233, 262, 282], animals [144, 146, 207] and in the perfused liver [232]. To measure synthetic rate it is necessary to measure over the same time interval total radioactivity (dpm <sup>14</sup>C) of a labelled amino acid

that enters the protein and average specific activity of the amino acid (dpm  $^{14}\text{C}$  per mg) at the synthetic site. The latter gives difficulty and, in living animals, requires a probe of the specific activity of the amino acid at the synthetic site. It was shown that if arginine-6- $^{14}\text{C}$  was used as the labelled amino acid, specific activity of synthesized urea- $^{14}\text{C}$  would provide an adequate probe [208]. Initially arginine-6- $^{14}\text{C}$  was injected into the blood stream, but technical problems result from entry of high specific activity arginine-6- $^{14}\text{C}$  into gamma globulins which contaminate the liver proteins under study [144] and from other causes [203]. Injection of bicarbonate- $^{14}\text{C}$  was proposed as an alternative approach [144]. This allows  $^{14}\text{C}$  to enter the urea cycle via carbamyl phosphate, synthesis in the liver of arginine-6- $^{14}\text{C}$ , its incorporation into newly synthesized proteins and formation from it of urea- $^{14}\text{C}$ . Thus, again, specific activity of synthesized urea- $^{14}\text{C}$  can act as a probe of the specific activity of arginine-6- $^{14}\text{C}$  at the synthetic site. This approach obviated the above mentioned technical difficulties, but now the difficulties of determining the average specific activity of the newly synthesized urea- $^{14}\text{C}$  became very apparent [150, 214]. These are due to several causes, particularly the large reservoir of urea in the animal body [150], the rapid metabolism of urea by intestinal bacteria [214] and the quite rapid inducibility of enzymes of the urea cycle, for instance by levels of dietary protein [237]. The result is that the specific activity of newly synthesized urea- $^{14}\text{C}$ , whether complicated and sometimes inappropriate kinetic approaches [207] are used, or whether a mass balance approach is used [207], becomes difficult and demanding to measure. The arginine-6- $^{14}\text{C}$  method is thus unsuited to use except in highly skilled laboratories.

In view of this we have tried a new approach based on findings of earlier workers [120]. This uses the specific activity of blood "total  $\text{CO}_2$ " as an indicator of the specific activity of the arginine-6-C at the synthetic site [207]. Thus the specific activity of an input to, rather than an output from, the synthetic site is used as a measure of the specific activity at the synthetic site. Good agreement was established between this new "total  $\text{CO}_2$ " input form and the old urea carbon output form of the method [207]. However, this method was still too complicated for general use. Fortunately, we have recently provided better kinetic analysis and introduced simplifications which should make the method generally useful [206].

*Mass balance method of measuring fibrinogen secretion rate:* The peculiarities of the fibrinogen system, in particular the relative constancy of  $j_3$ , as noted earlier allow a second approach to measuring fibrinogen secretion. Thus if we can accept as a fair picture of the fibrinogen system the core fibrinogen model, know the values of  $j_1$ ,  $j_2$  and  $j_3$  (or when significant  $j_3 + \theta_1 + \theta_2 + \pi$ ) then repeated measurements of plasma fibrinogen level at intervals of a few hours with a knowledge of plasma volume will allow calculation of fibrinogen secretion rate [46]. For instance in a rabbit, if at time  $t_1$  300 mg of fibrinogen are in the plasma and 350 mg at time  $t_2$ , four hours later; if 100 mg are in the interstitial fluids at  $t_1$  and 120 mg at  $t_2$ ; and if over four hours 7% of the mean plasma fibrinogen is broken down or  $0.07(650/2) = 22.75$  mg; then by mass balance methods total fibrinogen formed in four hours is  $(350-300) + (120-100) + 22.75 = 92.75$  mg. Thus the rate of formation in this brief interval of active synthesis is  $556.5$  mg/day, compared with the initial rate before  $t_1$  of  $j_3 t_p = .42(300) = 126$  mg/day; thus fibrinogen secretion rate has increased by 442%. For studies with this method we have usually obtained seven

plasma samples separated by four-hour intervals over 24 hours. We have recently examined this approach critically, using Monte Carlo simulation methods on a digital computer [46]. It turns out, as noted above, that \*I-fibrinogen measurements of  $j_3$  or  $J$  are accurate, but those of  $j_1$  and  $j_2$  quite inaccurate. Thus mean values of  $j_1$  and  $j_2$  are best taken rather than individual measurements, and simulation shows that errors from taking these mean values are not great. Preliminary experiments are done with \*I-fibrinogen to define  $j_3$  or  $J$  in the experimental conditions under study. Major changes in  $J$ , as for instance might occur with fibrinogenolysis, rarely occur in rabbits, perhaps because of the normal low levels of plasminogen in this animal [246]. Simulation shows little error results from taking a mean value for  $j_3$  or  $J$ . It further shows that the main source of error in this mass balance method is imprecise measurement of plasma fibrinogen concentration. Even with the isotope dilution method with coefficient of variation of 2.2% [46], errors in measurement of a four-hour change in fibrinogen secretion rate can amount to 30% or more [46]. The mass balance method is at its best in measuring average fibrinogen secretion rate over 24 hours, which it can do with a coefficient of variation of 10 to 15%, and it is directly applicable to many nonsteady state conditions. Studies with this method have provided an unexpected bonus. We found, given values of the  $j$ 's, that nearly as good an estimate of average 24-hour fibrinogen secretion rate was obtained from an initial measurement of plasma fibrinogen and a second measurement 24 hours later as from measurements made on seven plasma samples obtained at four-hour intervals over 24 hours [47]. Thus a simple assay of substances that stimulate fibrinogen synthesis in the second stage of the acute phase fibrinogen response, based on measurements of plasma fibrinogen levels separated by 24 hours, becomes available. Other required features of this assay are described later.

### The Acute Phase (AP) Fibrinogen Response

Fibrinogen is one of the plasma proteins that shows an "acute phase response," that is, following surgical trauma or the injection of endotoxin or acute infections plasma fibrinogen shows over 24 to 72 hours, depending on the species studied, a rise in concentration to twofold initial levels or more. Other proteins showing marked rises are C-reactive protein, antichymotrypsin, haptoglobin, orosomucoid and  $\alpha_1$ -antitrypsin [6]. These are all synthesized by the liver and contain 5 to 20% carbohydrate [118]. Owen [188] has reviewed earlier work on the effects of injury on plasma protein concentration, and excellent quantitative studies on the plasma protein response to injury in man have recently appeared [6, 49]. The former authors showed that the average response to cholecystectomy was a rise in plasma fibrinogen by 31% of initial level on the first postoperative day, by 74% on the second, by 87% on the third, maintenance near this level till the tenth postoperative day and thereafter a gradual fall to 20% above initial levels on the 20th postoperative day.

Diagrammatically shown in Figure 5 is the plasma fibrinogen response to an effective stimulus such as a three-hour infusion of ACTH [47] in a healthy rabbit. The response may be divided into four stages, though the fourth stage is not shown. The first stage is a brief quiescent period [12]: the second stage is a rapid rise in

Stages of Plasma Fibrinogen ( $\phi$ ) AP Response

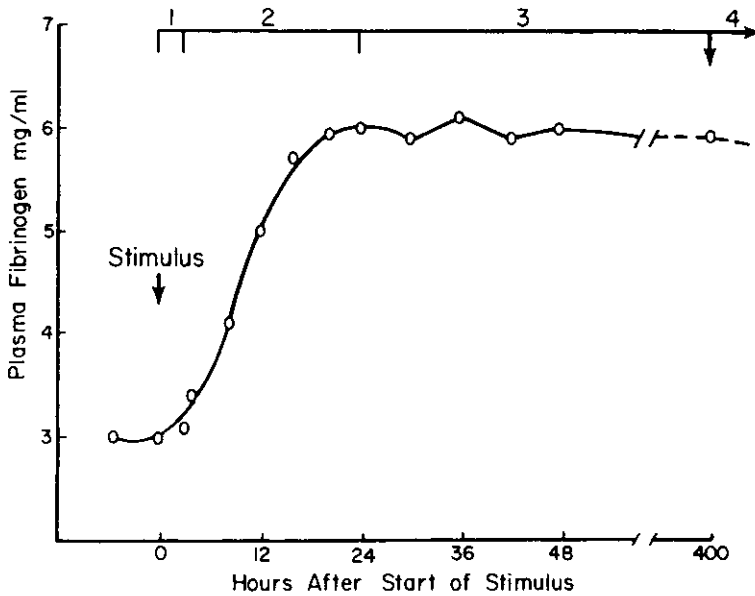

FIG. 5: A typical acute phase plasma fibrinogen response in a rabbit. It is separated into 4 stages: 1, an initial brief delay; 2, the onset of a sharp rise in plasma fibrinogen concentration, 3, a persisting raised level of plasma fibrinogen, and 4, (not shown) the decline of plasma fibrinogen to initial levels.

plasma fibrinogen level, for instance to twice initial levels: the third stage is maintained raised level of plasma fibrinogen, shown in Figure 5 at twice initial levels; and the fourth stage is return to initial (normal) levels. In rabbits, the second stage of the response usually lasts less than a day and repetition of the effective stimulus in the next few days after a marked response may cause little or no increase in fibrinogen level [12]. The third stage of the response can persist for weeks or months in an ill animal or human.

*The Second Stage of the AP Fibrinogen Response*

By definition, the second stage of the AP fibrinogen response is a relatively rapid rise in plasma concentration in response to an effective stimulus. Extensive clinical and some experimental observations have been made of the second stage of the AP fibrinogen response in man [118], and other studies have been reported in the rat [75] and dog [66]. We find the white New Zealand rabbit is very sensitive and convenient for study, but the animals must be healthy as judged by their appetites, weight gains, coat appearances, absence of evidence of infections and normal blood hematocrit and plasma fibrinogen levels. They must also become accustomed to their quarters and to repeated gentle handling. Though we have at times given animals tranquilizers (e.g., Sparine [47]) in their drinking water, as good results are obtained with kind and considerate treatment.

In our experience of rabbits, a significant second stage AP fibrinogen response is an increase greater than 0.8 mg fibrinogen/ml over 24 hours. With strong stimuli.

increases as great as 4 mg/ml or more may be seen [12]. Effective stimuli for such increases in various animals are local inflammation as from turpentine injection [66], thermal or mechanical injury [57], vaccine injection [83, 119], bacterial infection [83] and injection of tumor fragments [97]. Even very simple stimuli may produce a profound response. Thus Bocci et al. [30] show a plasma fibrinogen level increasing from 4.5 to 9.5 mg/ml, apparently as a result of four subcutaneous injections of physiologic saline given over eight hours. Subcutaneous injection of very large doses of adrenaline in rats also causes sharp increases in plasma fibrinogen level [94]. It seems likely that humoral factors are responsible for these plasma fibrinogen increases. Thus Chen finds that denervating the rabbit ear does not inhibit the fibrinogen response to a local ear burn, whereas arresting the circulation of the ear does [45].

In studies with relatively crude biological preparations, other investigators have found that infusions of large quantities of plasmin digestion products of fibrinogen stimulate the second stage of the AP fibrinogen response [18, 30]—though not apparently products released by human Thrombolysin acting on rabbit fibrinogen [241], injection of lysosomes isolated from normal white cells may have effect [118], injection of “peptone” [66] or antibody-antigen complexes [148] give a positive response, as do injections of neuraminidase [218]. We have not found injections of rabbit blood clot liquor to have any effect.

#### *The Second Stage of the AP Fibrinogen Response and Increased Synthesis*

Where it has been studied [12, 14, 46, 47, 119] the second stage of the AP fibrinogen response has been shown to be caused by a rapid burst of fibrinogen synthesis starting about two hours after the onset of the stimulus [14, 47], reaching levels as high as 10- to 20-fold normal levels over a few hours [14] and falling off to twofold, or occasionally higher levels 16 to 24 hours after the stimulus. At this time it may be maintained during the third stage of the response. It seems probable that in all instances where a rapid, considerable rise in plasma fibrinogen level occurs, that is in all instances where a clear cut AP fibrinogen response is seen, the underlying basis of the response is a marked increase in fibrinogen synthesis. Significant changes in fibrinogen catabolic rate are often not seen during such stimulation of synthesis [46, 47], but they may follow stimulation of  $\theta$  and  $\pi$  paths, as after endotoxin [128]. Figure 6 shows the time course of a typical acute phase fibrinogen response taken from the studies of Chen and Reeve [47]. The synthetic rates were measured by the mass balance procedure and were averaged over four-hour periods. It is seen that a maximum secretion rate of five times initial levels is achieved between two and six hours after concluding a two-hour intravenous infusion of 20 units ACTH per kg. This level is maintained for the next eight hours, after which it starts to fall, and by 20 to 24 hours after the start of the infusion, it has fallen near to levels that can maintain the third stage of the AP fibrinogen response. Atencio and Lorand [14] made studies by a less direct method of measuring secretion rate following subcutaneous injection of 80 units ACTH gel. This, apart from ACTH, contains a gel medium which is also capable of stimulating fibrinogen synthesis [12], and subcutaneous injection will result in a somewhat different response time course than intravenous injection of ACTH only. They found that after about two hours, fibrinogen secretion rate started to rise

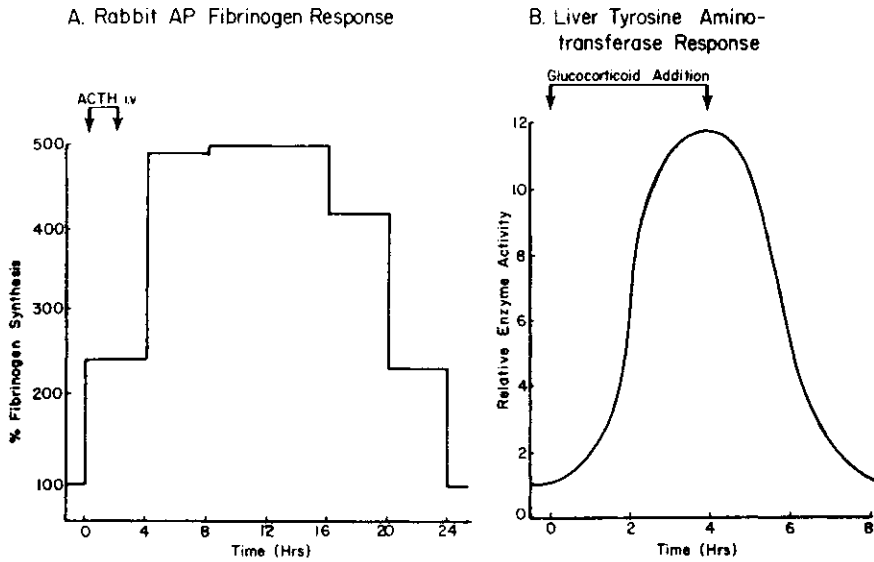

FIG. 6: Comparison of the average four-hourly fibrinogen secretion rates in response to a two-hour infusion of 20 units ACTH per kg in rabbits (Fig. 5A), with the formation of tyrosine aminotransferase by liver hepatoma cells in tissue culture in response to the addition of glucocorticoid to the medium during the first four hours and its removal by washing the cell culture during the second four hours.

rapidly, and between four and six hours after the injection, spiked at a level about 24 times initial secretion rate. It then fell back rapidly to a rate five to six times initial levels, which persisted between 10 and 24 hours after the ACTH gel injection. Thus the second stage of the AP fibrinogen response is characterized by overshoot. It appears as if the purpose of this stage is to raise plasma fibrinogen rapidly to limit immediate risk of hemorrhage. It is also clear that the animal cannot maintain these high levels of fibrinogen synthesis without overtaxing the liver's synthetic capacity [13].

*Search with the Rabbit Assay for AP Stimulators of Fibrinogen Secretion*

As noted above, this assay in the young male New Zealand rabbit after preliminary <sup>125</sup>I-fibrinogen studies requires plasma fibrinogen sampling at zero time, followed by two- or three-hour constant rate infusion of the test substance, followed in turn by plasma fibrinogen sampling at 24 hours [47]. Plasma fibrinogen concentrations are corrected for change in plasma volume by hematocrit. Given values of  $j_1$ ,  $j_2$  and  $j_3$  and accurate measurements of plasma fibrinogen, good estimates of average fibrinogen secretion rate over 24 hours are obtained. We now report studies with this method, some previously unpublished.

A minimal effective dose of ACTH is about 5 i.u. per kg; the maximal effective dose is about 20 i.u./kg body weight. These doses give about 1000-fold to 10,000-fold the normal levels of ACTH in the rabbit [47]. A quantitative model has been described relating dose to response [47]. Another approach has been used by other investigators [241]. The responses are completely blocked by cycloheximide infusion within a few hours of the ACTH infusion. They are inhibited by

concurrent infusion of actinomycin D, but not by infusion after a delay of eight to 12 hours [47]. Actinomycin D only blocks the second stage acute phase response, but not the resting secretion rate of fibrinogen; cycloheximide blocks both. The ACTH peptide ACTH<sup>1-23</sup> is fully effective, ACTH<sup>1-17</sup> has about one-third the activity of ACTH<sup>1-39</sup> and ACTH<sup>1-10</sup> is ineffective. Metyrapone, which stimulates endogenous ACTH secretion is without effect, but large doses of dexamethasone stimulate the response. The ACTH response does not depend on intact adrenals [128]. These results show that the second stage AP response to ACTH depends on new synthesis and suggest, contrary to other findings [111], that fibrinogen mRNA is quite long-lived by standards of *E. coli* mRNA.

Glucagon, insulin, growth hormone, vasopressin, pitressin tannate are not stimulators of the second stage of the AP fibrinogen response.

The intimate links between raised levels of fibrinogen and inflammation [148] suggest "inflammatory hormones" might be stimulatory of the AP fibrinogen response. Studies with the rabbit assay of intravenous infusion of histamine, bradykinin, serotonin and noradrenaline showed no effect, while adrenaline showed a variable effect, with an occasional response occurring, as if an extra factor were required apart from the adrenaline. However, prostaglandin E<sub>1</sub> infused intravenously i.v. for three hours in doses of 1.5 to 2.0 mg/kg body weight led to a very marked fibrinogen response and an observable response at 0.5 mg/kg [67]. Calculated PGE<sub>1</sub> hepatic blood concentration was 10 to 20 times the concentration effective in mobilizing fat, and, therefore, much nearer physiologic levels than the effective doses of ACTH noted above. Equivalent doses of other prostaglandins, e.g., PGE<sub>2</sub>, are ineffective, but of PGA<sub>1</sub> kill the animals. PGE<sub>1</sub> is released from many tissues on injury [280], but is required in rather large dosage to increase capillary leakiness or paw swelling [164]. However, when PGE<sub>1</sub> is given in smaller doses with bradykinin or histamine, capillary leakiness or paw swelling results [164, 280]. Thus PGE<sub>1</sub> in physiologic doses seems to promote the effects of these other "inflammatory hormones." We are now making studies to see if this is also true of the fibrinogen response.

We have found that extracts of human urine stimulate the second stage AP fibrinogen response. Thus 80 ml of sterile human urine infused into the rabbit lead to a sharp response. Extraction by ethanol precipitation followed by gel permeation chromatography separated two active fractions, one with MW greater than 10,000 daltons, the other with MW less than 1,000. The latter gives opportunity for isolation and synthesis and, currently, we find it can be separated into an active fibrinogen synthesis stimulating substance (FSS) and a fibrinogen synthesis inhibiting substance (FIS), both of very similar physico-chemical properties and in equilibrium with each other. We are now trying to establish that these natural hormones are active in the normal regulation of fibrinogen synthesis, and that a switch between FSS and FIS is used to regulate the level of plasma fibrinogen.

*Similarities between the AP Fibrinogen Response  
and the Response of Some Intracellular Liver Enzymes  
to Large Doses of Hormones*

Liver export proteins are not the only liver proteins to show an acute phase type of response. This may also be seen with some intracellular proteins, such as



tyrosine aminotransferase (TAT). Figure 6. When large doses of hydrocortisone are injected into animals [237] or cultures of hepatoma cells are incubated with glucocorticoid, after a delay, TAT starts to rise. In tissue culture, after a two-hour delay, TAT may increase tenfold over the next two hours and persist at these levels during glucocorticoid incubation. Washing the cells free of glucocorticoid results in a fall over the following four hours to initial levels [237]. Figure 6. The rise in TAT is due to increased synthesis, not to reduced catabolism. Figure 6 compares the second stage AP fibrinogen response with the tissue culture TAT response. The latter seems controlled by the level of glucocorticoid; the explosive response of the former seems initiated by one or another of a variety of effective stimuli, but unlike the TAT response *in vitro*, the second stage AP fibrinogen response seems self-limited *in vivo*. It also shows tachyphylaxis on repeated stimulation, and recovery of the full response seems to require seven days or so after an effective stimulus [12]. The fibrinogen response is inhibited by giving actinomycin D with the infusion of ACTH [47], but actinomycin D has more than one effect. An attractive but probably incorrect explanation of the second stage AP fibrinogen response would be release of stored fibrinogen mRNA, which could only slowly be built back into the store sites. This would rapidly, but because of mRNA catabolism, temporarily, raise plasma fibrinogen level and then permit the independent mechanisms of the third stage of the AP fibrinogen response to take over.

#### *The Third Stage of the Acute Phase (AP) Fibrinogen Response*

During this stage, as Figure 5 shows, plasma fibrinogen fluctuates about a raised level. Since increased erythrocyte sedimentation rates (ESR), which are particularly dependent on raised plasma fibrinogen levels [281], may persist for long periods in many chronic diseases, raised levels of fibrinogen may persist for months or years. Equation 1 shows that if plasma fibrinogen level remains about constant and, as has to occur over more than a brief period,  $j_1 \bar{r}_p = j_2 \bar{r}_c$ , then  $S$ , synthetic rate of fibrinogen =  $J \bar{r}_p$ . Since  $\bar{r}_p$  is by definition plasma volume multiplied by plasma fibrinogen concentration, as a first approximation,  $S$  will vary directly as plasma fibrinogen concentration. This may be modified by change in plasma volume, which usually increases in chronic diseases [281] and by what happens to  $J$ .  $j_3$  is assumed not to change. However, if fibrinogen efflux from the plasma increases because of opening  $\theta_1$ ,  $\theta_2$  or  $\pi$  paths, then  $S$  will proportionately increase. Table 3 summarizes some common diseases in which the third stage of the AP fibrinogen response is activated and adds comments about activation of the  $\theta_1$ ,  $\theta_2$  and  $\pi$  paths and about fibrinogen synthesis. Clearly, the levels of plasma fibrinogen during the second and third stages of the AP fibrinogen response depend on the interaction between all the mechanisms shown in Figure 1; that is, between the mechanisms altering fibrinogen efflux and those stimulating fibrinogen synthesis. The factors driving the increased synthesis of fibrinogen during the third stage of the AP response seem almost certainly hormonal. Whether these factors are the same hormones that stimulate the second stage, or whether they are different hormones, we currently do not know. It appears likely to us that they are different hormones, in which case our current rabbit assay is not very sensitive in detecting them. As these third stage

TABLE 3. Plasma Fibrinogen and Fibrinogen Effluxes in Representative Diseases

	Normal $f_p$ ‡	Increased $f_p$	Decreased $f_p$
$J=j_3$ ( $\pi=0$ ) ( $\Theta_2=0$ )	Normal subjects [255], n=12 $f_p=127\pm 5$ † $J=.246\pm .005$ $Jf_p=31.3\pm 1.4$	Rheumatoid arthritis [254], n=11 $f_p=329\pm 63$ $J=.266\pm .009$ (normal) $Jf_p=89\pm 18$ Occurs in many chronic diseases.	No data found. Could result from a "pure" synthetic defect.
(J increased) $\pi$ increased ( $\Theta_2=0$ )	No data found. Could occur if $\pi f_p$ were exactly matched by increased synthesis.	Hemophilia [258], n=12 $f_p=144\pm 9$ $J=.358\pm .010$ $\pi=.112$ (est. from $J-j_3$ ) $Jf_p=105\pm 13$ Chronic fibrinogenolysis (see text)	Leukemia [210], single study $f_p=31.3$ $J=1.6$ $\pi=1.35$ $Jf_p=113$ Subacute fibrinolysis (see text)
(J increased) ( $\pi \geq 0$ ) $\Theta_2$ increased	Cirrhosis [268], n=50 $f_p=119\pm 7$ (normal) $J=.34\pm .01$ $Jf_p=39\pm 3$ Chronic intravascular coagulation	Cancer [69], n=14 $f_p=324\pm 42$ $J=.305\pm .012$ $\Theta_2=.076\pm .008$ $\pi=0$ $Jf_p=105\pm 13$ Chronic intravascular coagulation (see text)	Subacute intravascular coagulation. Many cases published (see text) but with insufficient data to calculate $J$ , $\Theta_2$ and $\pi$ .

‡  $f_p$  = intravascular fibrinogen in mg/kg;  $j_3$  = normal fractional catabolic rate in days<sup>-1</sup>;  $\pi$  = rate of lysis of plasma fibrinogen by plasmin in days<sup>-1</sup>;  $\Theta_2$  = rate of conversion of plasma fibrinogen to fibrin in days<sup>-1</sup>;  $J = j_3 + \pi + \Theta_2$  and  $Jf_p$  = total plasma fibrinogen efflux in mg/kg/day. In the steady state,  $Jf_p = S$ , the fibrinogen synthetic rate. Note that  $Jf_p$  is increased in all pathologic conditions, even when  $f_p$  is low. (Possible exception is Arvin® or Reptilase® defibrination, see text.)

† Standard error of the mean.

hormones are of great importance in regulating prolonged raised plasma fibrinogen levels. development of good assays for them becomes important.

### Interactions of Fibrinogen Synthesis with the Sum of the Fibrinogen Fluxes.

#### Regulation of the Complete Fibrinogen System

The fibrinogen effluxes are defined by the products  $j_3 f_p$ ,  $\theta_1 f_p$ ,  $\theta_2 f_p$  and  $\pi f_p$ . Clearly, the effect of increases in  $\pi$  or  $\theta_2$  on the corresponding fluxes may be enhanced or nullified by a rise or fall in  $f_p$ , plasma fibrinogen. The direction of change of  $f_p$  depends on 1) stimuli to the liver to increase production, and the liver's ability to respond to these stimuli and 2) the magnitude of  $Jf_p$ , the sum of all the irreversible fluxes of fibrinogen out of  $f_p$ . The linear relationship between  $J$  or any of its components and  $Jf_p$  and its components ( $j_3 f_p$ ,  $\theta_1 f_p$ ,  $\theta_2 f_p$  and  $\pi f_p$ ) provides a powerful, if inflexible, control system, which conserves circulating fibrinogen when  $f_p$  begins to fall. However, as described above, the ability of the liver to respond quickly to synthetic stimuli provides the most important and flexible mechanism for controlling fibrinogen levels in the plasma. As noted above, Equations 1 and 2 show that in a steady state,  $S = Jf_p$ . Thus if the efflux,  $Jf_p$ , is increased, then  $S$ , the fibrinogen secretion rate, must also be increased. Table 3 presents a number of examples of this interaction between the rate of fibrinogen secretion and alterations in the degradative effluxes in several representative clinical conditions. It shows that in fibrinogenolysis or intravascular coagulation from any cause, the circulating fibrinogen,  $f_p$ , may be high, normal or low depending on the hepatic secretion response to the challenge of the disease.

The complete fibrinogen system presents difficult control problems to the animal organism. Thus if plasma fibrinogen falls too low, bleeding ensues; while if it rises too high, blood viscosity greatly increases, the risk of thromboembolism increases and the synthetic effort placed on the liver may render inadequate liver synthesis of other essential proteins. Clearly then, to avoid disaster to the organism, the complete fibrinogen system must have some degree of regulation; that is, there must be some degree of feedback between parameters related to plasma fibrinogen and rate of liver synthesis of fibrinogen. Feedback in this case would seem to be managed by hormonal information systems, but the foregoing sections of this review show that our knowledge of these is minimal. Level of plasma fibrinogen itself does not exert any negative feedback [13, 212]. However, large amounts of plasmin digestion products of fibrinogen, which would ordinarily be associated with a fall in plasma fibrinogen levels, do stimulate fibrinogen secretion [18, 30]. Some inflammatory hormones, such as prostaglandin  $E_1$ , may serve to reset the rate of fibrinogen secretion by increasing the number of liver cells actively secreting it. The mechanisms by which the powerful stimulators ACTH and endotoxin act on the liver are unknown.

The foregoing three sentences summarize current knowledge of chemical (hormonal) regulation. How the complete fibrinogen system is regulated so that it functions for the most part well over very many years, and in what ways this system may go wrong, presents an irresistible challenge to many investigators, both because of the intrinsic interest of the underlying mechanisms and the therapeutic

advances that would result from their better understanding. We hope this review will encourage new investigators to join the ranks of those who already have so much enjoyment in their studies in this field.

## REFERENCES

1. Abercrombie A, RD Harkness: The growth of cell populations and the properties in tissue culture of regenerating liver of the rat. *Proc Roy Soc B* 138:544-561, 1951.
2. Abildgaard U: Antithrombins. *Thromb Diath Haemorrh Suppl* 51:295-298, 1972.
3. Abildgaard U: Inhibition of the thrombin-fibrinogen reaction by  $\alpha_2$ -macroglobulin, studied by N-terminal analysis. *Thromb Diath Haemorrh* 21:173-180, 1969.
4. Agostino D, EE Clifton: Fibrinogen levels and pulmonary metastases in rats. *Arch Pathol* 87:141-145, 1969.
5. Ambrus JL, CM Ambrus, L Stutzman, G Schmort, R Jacobsen, JM Schor, J Jarnchill: Therapeutic studies with fibrinolytic and antifibrinolytic agents. *In: JM Schor (Ed): Chemical Control of Fibrinolysis*. Wiley, New York, 1970, pp 153-203.
6. Aronsen K-F, G Ekelund, C-O Kindmark, C-B Laurell: Sequential changes of plasma proteins after surgical trauma. *Scand J Clin Lab Invest* 29, suppl 124:127-136, 1972.
7. Astrup T: Blood coagulation and fibrinolysis. An ubiquitous defense mechanism of multiple regulated pathways. *Thromb Diath Haemorrh, Suppl* 54:83-114, 1973.
8. Astrup T, S Thorsen: The physiology of fibrinolysis. *Med Clin North Am* 56:153-162, 1972.
9. Astrup T: Tissue activators of plasminogen. *Fed Proc* 25:42-51, 1966.
10. Atencio AC, HR Bailey, EB Reeve: Studies on the metabolism and distribution of fibrinogen in the young and older rabbits. I. Methods and models. *J Lab Clin Med* 66:1-19, 1965. II. Results. *Loc Cit* 66:20-33, 1965.
11. Atencio AC, DC Burdick, EB Reeve: An accurate isotope dilution method for measuring plasma fibrinogen. *J Lab Clin Med* 66:137-145, 1965.
12. Atencio AC, P-Y Chao, A Chen, EB Reeve: Fibrinogen response to corticotropin preparations in rabbits. *Am J Physiol* 216:773-780, 1969.
13. Atencio AC, K Joiner, EB Reeve: Experimental and control systems studies of plasma fibrinogen regulation in rabbits. *Am J Physiol* 216:764-772, 1969.
14. Atencio AC, L Lorand: Effect of ACTH on biosynthesis of fibrinogen in the rabbit. *Am J Physiol* 219:1161-1165, 1970.
15. Atkins IGL: *Multicompartment Models for Biological System*. Methuen, London, 1969.
16. Atkins P, LA Hawkins: Detection of venous thrombosis in the legs. *Lancet* 2:1217-1219, 1965.
17. Barnhart MI, DC Cress, SM Noonan, RT Walsh: Influence of fibrinolytic products on hepatic release and synthesis of fibrinogen. *Thromb Diath Haemorrh Suppl* 39:143-159, 1970.
18. Barnhart MI, SM Noonan: Cellular control mechanisms for blood clotting proteins. *Thromb Diath Haemorrh Suppl* 54:59-82, 1973.
19. Bell WR, E Regoeczi: Isotopic studies of therapeutic anticoagulation with a coagulating enzyme. *J Clin Invest* 49:1872-1879, 1970.
20. Bergner P-F E, CC Lushbaugh: *Compartments, Pools and Spaces in Medical Physiology*. US Atomic Energy Commission, Division of Technical Information, 1967, pp 1-529.
21. Berson SA, RS Yalow, SS Schreiber, J Post: Tracer experiments with  $^{1131}$  labeled human serum albumin: distribution and degradation studies. *J Clin Invest* 32:746-768, 1953.
22. Biggs R, RG MacFarlane, J Pilling: Observations on fibrinolysis. Experimental production by exercise or adrenaline. *Lancet* 1:402-404, 1947.
23. Bissell DM, JG Tilles: Radioimmunoassay of serum albumin produced by human embryonic liver in monolayer culture. *J Cell Biol* 53:819-823, 1972.
24. Blombäck B: Fibrinogen to fibrin transformation. *In: WH Seegers (Ed): Blood Clotting Enzymology*. Academic Press, New York, 1967, pp 143-215.

25. Blombäck B: Incorporation of  $^{131}\text{I}$  into dog fibrinopeptides. *Acta Chem Scand* 23:1137-1144, 1969.
26. Blombäck B, M Blombäck: Purification of human and bovine fibrinogen. *Arkiv Kemi* 10:415-443, 1956.
27. Blombäck B, LA Carlson, S Franzen, E Zetterqvist: Turnover of  $^{131}\text{I}$ -labelled fibrinogen in man. Studies in normal subjects, in congenital coagulation factor deficient states, in liver cirrhosis, in polycythemia vera and in epidermolysis bullosa. *Acta Med Scand* 179:557-574, 1966.
28. Blombäck B, E Zetterqvist: Incorporation of  $^{131}\text{I}$  into dog fibrinopeptides. *Acta Chem Scand* 23:1137-1144, 1969.
29. Bocci V: Metabolism of plasma proteins. *Arch Fisiol* 67:314-444, 1970.
30. Bocci V, A Pacini: Factors regulating plasma protein synthesis. II. Influence of fibrinogenolytic products on plasma fibrinogen concentration. *Thromb Diath Haemorrh* 29:63-75, 1973.
31. Boggust WA, DJ O'Brien, RAQ O'Meara, RD Thomes: The coagulative factors of normal human and human cancer tissue. *Irish J Med Sci* 447:131-144, 1963.
32. Boggust WA, RAQ O'Meara, RD Thomes: The coagulative factors of normal human and cancer tissue. *Biochem J* 80:32p, 1961.
33. Bolton AE, WM Hunter: The labelling of proteins to high specific radioactivities by conjugation to a  $^{125}\text{I}$ -containing acylating agent. *Biochem J* 133:529-539, 1973.
34. Bond RE, JV Donadio Jr, KE Holley, EJ Bowie: Fibrinolytic split products. A clinicopathological correlative study in adults with lupus glomerulonephritis and various renal diseases. *Arch Intern Med* 132:182-187, 1973.
35. Bosch L (Ed): The mechanism of protein synthesis and its regulation. American Elsevier, New York, 1972.
36. Browse NL: The  $^{125}\text{I}$ -fibrinogen uptake test. *Arch Surg* 104:160-163, 1972.
37. Bruns RR, GE Palade: Studies on blood capillaries. I. General organization of blood capillaries in muscle. *J Cell Biol* 37:244-276, 1968.
38. Bruns RR, GE Palade: Studies on blood capillaries. II. Transport of ferritin molecules across the wall of muscle capillaries. *J Cell Biol* 37:277-299, 1968.
39. Bull BS, ML Rubenberg, JV Dacie, MC Brain: Microangiopathic haemolytic anemia: Mechanisms of red-cell fragmentation: *in vitro* studies. *Br J Haematol* 14:643-652, 1968.
40. Busch C, T Saldeen: Amount of fibrin in different organs after intravenous, intraportal and intraaortal injection of thrombin in the rat. *Thromb Diath Haemorrh* 29:87-93, 1973.
41. Campbell RM, DP Cuthbertson, CMF Matthews, AS McFarlane: Behaviour of  $^{14}\text{C}$  and  $^{131}\text{I}$ -labelled plasma proteins in the rat. *Int J Appl Radiat Isotopes* 1:66-84, 1956.
42. Caro LG, GE Palade: Protein synthesis, storage and discharge in the pancreatic exocrine cell. *J Cell Biol* 20:473-495, 1964.
43. Cash JD: Effect of moderate exercise on the fibrinolytic system in normal young men and women. *Br Med J* 2:502-504, 1966.
44. Charm SE, GS Kurland: Blood Flow and Microcirculation. John Wiley, New York, 1974.
45. Chen AY: unpublished observations.
46. Chen Y, FW Briese, EB Reeve: Simplified method for serial estimation of fibrinogen secretion rate. *Amer J Physiol*, 1974 (in press).
- 47a. Chen Y, FW Briese, EB Reeve: Relation of fibrinogen secretion to ACTH dose. *Am J Physiol*, 1974 (in press).
- 47b. Chen Y, EB Reeve: Further studies of ACTH stimulation of fibrinogen biosynthesis. *Amer J Physiol*, 1974 (in press).
48. Chien S, S Usami, RJ Dellenback, MI Gregersen: Influence of fibrinogen and globulins on blood rheology at low shear rates. In: B Hartert, AL Copley (Eds): *Theoretical and Clinical Hemorheology*. Springer, Heidelberg, 1971, pp 136-153.
49. Clarke HGM, T Freeman, R Hickman, WFM Pryse-Phillips: Serum protein changes after injury. *Clin Sci* 40:337-394, 1971.
50. Clementi F, GE Palade: Intestinal capillaries. I. Permeability to peroxidase and ferritin. *J Cell Biol* 41:33-58, 1969.

51. Collen D, N Semeraro, M Verstraete: The fibrinolytic pathway of fibrinogen catabolism: A reply. *Thromb Res* 4:491-496, 1974.
52. Collen D, GN Tytgat, H Claeys, R Piessens: Metabolism and distribution of fibrinogen. I. Fibrinogen turnover in physiological conditions in humans. *Br J Haematol* 22:681-700, 1972.
53. Collen D, G Tytgat, H Claeys, M Verstraete, P Wallen: Metabolism of plasminogen in healthy subjects: Effect of tranexamic acid. *J Clin Invest* 51:1310-1318, 1972.
54. Cooper HA, EJW Bowie, P Didsheim, CA Owen: Paradoxical changes in platelets and fibrinogen in chronically induced intravascular coagulation. *Mayo Clinic Proc* 46:521-523, 1971.
55. Daoust R: The cell population of liver tissue and the cytological reference bases. *In*: RW Brauer (Ed): *Liver Function, a symposium on approaches to the quantitative description of liver function*. American Institute of Biological Sciences, Washington, 1958, pp 3-10.
56. Davies JW, SO Liljedahl, P Reizenstern: Fibrinogen metabolism following injury and its surgical treatment. *Injury* 1:178-185, 1970.
57. Davies JW, CR Ricketts, JP Bull: Studies of plasma protein metabolism. III. Fibrinogen in burned patients. *Clin Sci* 30:305-314, 1966.
58. Dellenback RJ, S Usami, S Chien: Metabolism and distribution of homologous and autologous fibrinogen in beagle dogs. *Am J Physiol* 220:828-836, 1971.
59. Dewey WC, WF Bale, RG Rose, D Marrack: Localization of antifibrin antibodies in human tumors. *Acta Unio Int Cancer* 19:185-196, 1963.
60. Donato L, F Vitak, R Bianchi, G Federighi: A double tracer method for metabolic studies with iodinated proteins on polypeptides in presence of a relatively slow excretion of iodide. *J Nucl Biol Med* 11:1-8, 1967.
61. Egberg N, A Ljungqvist: On fibrin distribution in organs of dogs during defibrination with the thrombin-like enzyme from *Bothrops Atrox*. *Thromb Res* 3:191-207, 1973.
62. Ferguson JC, N MacKay, GP McNicol: Effect of fat feeding on fibrinolysis, stypven time and platelet aggregation in Africans, Asians and Europeans. *J Clin Pathol* 23:580-585, 1970.
63. Finlayson JS: Crosslinking of fibrin. *Semin. Thromb Hemost* 1:33-62, 1974.
64. Flanc C, VV Kakkar, MB Clarke: The detection of venous thrombosis of the legs using <sup>125</sup>I-labelled fibrinogen. *Br J Surg* 55:742-747, 1968.
65. Fletcher A, O Biederman, S Moore, N Alkjaersig, S Sherry: Abnormal plasminogen-plasmin activity (fibrinolysis) in patients with hepatic cirrhosis: Its cause and consequences. *J Clin Invest* 43:681-695, 1964.
66. Foster DP, GH Whipple: Blood fibrin studies. IV. Fibrin values influenced by cell injury, inflammation, intoxication, liver injury and Eck fistula. *Amer J Physiol* 58:407-431, 1922.
67. Fradl D, EB Reeve: Plasma fibrinogen response to prostaglandin infusions. *Fed Proc* 32 Abs:265, 1973.
68. Franks JJ, KW Edwards, WW Lackey, JB Fitzgerald: The role of the gut in albumin catabolism. II. Studies in enterectomized rabbits. *J Gen Physiol* 46:427-434, 1963.
69. Franks JJ, S Gordon, B Kao, T Sullivan, D Kirch: Increased fibrin formation with tumors and its genesis. Sixth Int Symp on Plasma Protein Turnover, Torino, Italy, May 22-25, 1974. To be published.
70. Franks JJ, B Kao, B Allen: Fibrin formation in patients with cancer. *Abstr XIV Int Congr Hematol* 1972, p. 290.
71. Freeman T: The biological behavior of normal and denatured human plasma albumin. *Clin Chim Acta* 4:788-792, 1959.
72. French JF, RG MacFarlane: Haemostasis and Thrombosis. *In*: Lord Florey (Ed): *General Pathology*. Saunders, Philadelphia, 1970, Chapter 9, pp 273-317.
73. Gans H, R Stern, BH Tan: On the in vivo clearance of thrombin. *Thromb Diath Haemorrh* 22:1-12, 1969.
74. Gitlin D, CA Janeway: Some isotopic studies on the distribution and metabolism of plasma proteins. *Adv Biol Med Phys* 7:249-293, 1960.
75. Gordon AH: The effects of trauma and partial hepatectomy on the rates of synthesis of plasma proteins by the liver. *In*: MA Rothschild, TA Waldmann (Eds): *Plasma Protein*

- Metabolism. Academic Press, New York, 1970, Chapter 22, pp 351-368.
76. Gordon AH, JM Humphrey: Measurement of intracellular albumin in rat liver. *Biochem J* 78:551-556, 1961.
  77. Gralnick HR, S Marchesi, H Gwelber: Intravascular coagulation in acute leukemia. Clinical and subclinical abnormalities. *Blood* 40:709-718, 1972.
  78. Gregersen MI: A practical method for the determination of blood volume with the dye T-1824. *J Lab Clin Med* 29:1266-1286, 1944.
  79. Griffin EE, LL Miller: Effects of hypophysectomy of liver donor on net synthesis of specific plasma proteins by the isolated perfused rat liver. *J Biol Chem* (in press).
  80. Griffin EE, LL Miller: Effects of hypothyroidism, hyperthyroidism, and thyroxine on net synthesis of plasma proteins by the isolated perfused rat liver. *J Biol Chem* 248:4716-4723, 1973.
  81. Grotte G: Passage of dextran molecules across the blood lymph barrier. *Acta Chir Scand Suppl* 211:1-84, 1956.
  82. Hall CE, HS Slayter: The fibrinogen molecule: Its size, shape, and mode of polymerization. *J Biophys Biochem Cytol* 5:11-16, 1959.
  83. Ham TH, FC Curtis: Plasma fibrinogen response in man. Influence of the nutritional state, induced hyperpyrexia, infectious disease and liver damage. *Medicine* 17:413-444, 1938.
  84. Hamashima Y, JG Harter, AH Coons: The localization of albumin and fibrinogen in human liver cells. *J Cell Biol* 20:271-279, 1964.
  85. Hanson H: Intracellular proteolysis and its demonstration with synthetic and natural peptides and proteins as substrates. *In*: PG Katsoyannis (Ed): *The Chemistry of the Polypeptides*. Plenum Press, New York, 1973, Chapter 11, pp 237-258.
  86. Harker LA, SJ Slichter: Platelet and fibrinogen consumption in man. *New Eng J Med* 287:999-1005, 1972.
  87. Harpel PC, MW Mossesson: Degradation of human fibrinogen by plasma  $\alpha_2$ -macroglobulin-enzyme complexes. *J Clin Invest* 52:2175-2184, 1973.
  88. Harrold AJ: Elimination of fibrinogen from synovial joints. *Ann Rheum Dis* 32:29-34, 1973.
  89. Hart HC: The biological half-life of  $^{131}$ I-fibrinogen. *Thromb Diath Haemorrh Suppl* 17:121-131, 1965.
  90. Hedner U: Urinary fibrin-fibrinogen degradation products (FDP) in renal diseases and during thrombolytic therapy. *Scand J Clin Lab Invest* 32:175-182, 1973.
  91. Hedner U, M Ekberg, IM Nilsson: Urinary fibrin-fibrinogen degradation products (FDP) and glomerulonephritis. *Acta Med Scand* 195:81-85, 1974.
  92. Hedner U, IM Nilsson: Clinical experience with the determination of fibrinogen degradation products. *Acta Med Scand* 189:471-477, 1971.
  93. Heimburger N, H Haupt, HG Schwick: Proteinase inhibitors of human plasma. *In*: H Fritz, H Tschesche (Eds): *Proc Int Res Conf on Proteinase Inhibitors*. Walter de Gruyter, New York, 1971, pp 1-22.
  94. Henriques SB, OB Henriques, A Levy: Slow hyperfibrinogenemic action of adrenaline and related substances. *Br J Pharmacol* 11:99-103, 1956.
  95. Hickman JA: Blood activity of  $^{125}$ I-fibrinogen in venous thrombosis. *Lancet* 2:469p, 1970.
  96. Hickman JA: Pharmacological enhancement of fibrinolytic activity and  $^{125}$ I-fibrinogen survival. *J Clin Pathol* 23:797-800, 1970.
  97. Hilgard P, V Hiemeyer: Increased plasma fibrinogen and the release of a fibrinogen enhancing factor in tumor-bearing rats. *Experientia* 26:182-183, 1970.
  98. Hinshelwood CN, A Dean: *Growth Function and Regulation in Bacterial Cells*. Clarendon Press, Oxford, 1960.
  99. Hiramoto R, J Bernecky, J Jurandowski, D Pressman: Fibrin in human tumors. *Cancer Res* 20:592-593, 1960.
  100. Hirsch J, AP Fletcher, S Sherry: Effect of fibrin and fibrinogen proteolysis products on clot physical properties. *Am J Physiol* 209:415-424, 1965.
  101. Hoagland MG: Coding, information transfer and protein synthesis. *In*: JB Stanbury, JB Wyngaarden, DS Fredrickson (Eds). *The Metabolic Basis of Inherited Disease*. McGraw-Hill, New York, 1972, Chapter 2, pp 29-51.

102. Hobbs JT, JWL Davies: Detection of venous thrombosis with  $^{131}\text{I}$ -labelled fibrinogen in the rabbit. *Lancet* 2:134-135, 1960.
103. Hughes WL: The chemistry of iodination. *Ann NY Acad Sci* 70:3-18, 1957.
104. Hunter WM, FC Greenwood: Preparation of iodine- $^{131}\text{I}$  labelled human growth hormone of high specific activity. *Nature (London)* 194:495-496, 1962.
105. Jackson AS: Analog Computation. McGraw-Hill, New York, 1960.
106. Jacob F, J Monod: Genetic regulatory mechanisms in the synthesis of proteins. *J Molec Biol* 3:318-356, 1961.
107. Jamieson JD, GE Palade: Intracellular transport of secretory proteins in the pancreatic exocrine cell. I. Role of the peripheral elements of the Golgi complex. *J Cell Biol* 34:577-596, 1967.
108. Jamieson JD, GE Palade: Intracellular transport of secretory proteins in the pancreatic exocrine cell. II. Transport to condensing vacuoles and zymogen granules. *J Cell Biol* 34:597-615, 1967.
109. Janoff A: Mediators of tissue damage in human polymorphonuclear neutrophils. *Ser Haemat* 3:96-130, 1970.
110. Jeyasingh K, B Maurer, DS Rosengarten, TR Verma: Decline of blood activity of  $^{125}\text{I}$ -fibrinogen in venous thrombosis. *Lancet* 1:294-296, 1970.
111. John DW, LL Miller: Influence of actinomycin D and puromycin on net synthesis of plasma albumin and fibrinogen by the isolated perfused rat liver. *J Biol Chem* 241:4817-4824, 1966.
112. Kaighn ME, AM Prince: Production of albumin and other serum proteins by clonal cultures of normal human liver. *Proc Nat Acad Sci USA* 68:2396-2400, 1971.
113. Kakkar VV, AN Nicolaides, JTG Renney, JR Friend, MB Clarke:  $^{125}\text{I}$ -labelled fibrinogen test adapted for routine screening for deep vein thrombosis. *Lancet* 1:540-542, 1970.
114. Kakkar VV: The diagnosis of deep vein thrombosis using the  $^{125}\text{I}$ -fibrinogen test. *Arch Surg* 104:152-159, 1972.
115. Kincaid-Smith P, BM Saker, KF Fairley: Anticoagulants in "irreversible" acute renal failure. *Lancet* 2:1360-1363, 1968.
116. King JB: Some recent advances in coagulation. *S Afr Med J* 46:2085-2089, 1972.
117. Kogler J, EB Reeve, JJ Franks, B Kao, S Walker: Removal rate of human subcutaneous  $^{125}\text{I}$ -fibrin. *Clin Res* 21:220, 1973.
118. Koj A: Synthesis and turnover of acute phase reactants. *In: R Porter, J Knight (Eds): Energy Metabolism in Trauma.* Ciba Foundation, Churchill, London, 1970, pp 79-88.
119. Koj A, AS McFarlane: Effect of endotoxin on plasma albumin and fibrinogen synthesis rates in rabbits as measured by the  $^{14}\text{C}$ -carbonate method. *Biochem J* 108:137-146, 1968.
120. Kornberg HL, RE Davies, DR Wood: The metabolism of  $^{14}\text{C}$ -labelled bicarbonate in the cat. *Biochem J* 51:351-357, 1952.
121. Kowalski E, M Kopec, Z Wegrzynowicz: Influence of fibrinogen degradation products (FDP) on platelet aggregation, adhesiveness and viscous metamorphosis. *Thromb Diath Haemorrh* 10:406-425, 1964.
122. Krohn K, L Sherman, M Welch: Studies of radioiodinated fibrinogen. I. Physicochemical properties of the ICl, chloramine-T, and electrolytic reaction products. *Biochim Biophys Acta* 285:404-413, 1972.
123. Kukral JC, R Zeineh, W Dobryszczyka, J Pollitt, N Stone: Turnover rates of fibrinogen in burned patients labelled with  $^{35}\text{S}$ -methionine. *Clin Sci* 36:221-230, 1969.
124. Kwaan HC: Disorders of fibrinolysis. *Med Clin North Am* 56:163-176, 1972.
125. Kwaan HC: Disseminated intravascular coagulation. *Med Clin North Am* 56:177-192, 1972.
126. Laki K (Ed): Fibrinogen. Marcel Dekker, New York, 1968. pp 1-398.
127. Laurell C-B: Electroimmuno Assay. *Scand J Clin Lab Invest* 29:Suppl 124:21-37, 1972.
128. Lerner RG, SI Rapaport, JK Siemsen, JM Spitzer: Disappearance of fibrinogen  $^{131}\text{I}$  after endotoxin; effects of a first and second injection. *Am J Physiol* 214:532-537, 1968.
129. Lew W, EB Reeve: Unpublished observations.
130. Lewis HZ, WM Wedel: Mimic: A simulation language for continuous dynamic systems.



- Dept. Electrical Engineering, Graduate Computer Center, University of Colorado, Boulder, Colo.
131. Lewis JH, ZF Szebo: Clearance of infused fibrin. *Fed Proc* 24:840-845, 1965.
  132. Liniger W, P Rueggsegger: A mathematical model of fibrinolysis. *Math Biosci* 1:263-285, 1967.
  133. Lorand L: Fibrinolytic: The fibrin stabilizing factor system of blood plasma. *Ann NY Acad Sci* 202:6-30, 1972.
  134. Magnusson S: Bovine prothrombin and thrombin. *In: GE Perlmann, L Lorand (Eds): Methods in Enzymology, XIX, Proteolytic Enzymes.* Academic Press, New York, 1970, pp 157-184.
  135. Manchester FL: Sites of hormonal regulation of protein metabolism. *In: HN Munro (Ed): Mammalian Protein Metabolism, Vol IV.* Academic Press, New York, 1970, Chapter 33, pp 229-298.
  136. Marchalonis JJ: An enzymic method for the trace iodination of immunoglobulins and other proteins. *Biochem J* 113:299-305, 1969.
  137. Marder VJ, AZ Budzynski: The structure of the fibrinogen degradation products. *In: TH Spaet (Ed): Progress in Hemostasis and Thrombosis, Vol. 2.* Grune & Stratton, New York, 1974, pp 141-174.
  138. Martinez J, SS Shapiro, RR Holburn: Metabolism of human prothrombin and fibrinogen in patients with thrombocytosis secondary to myeloproliferative states. *Blood* 42:34-46, 1973.
  139. Martinez J, SS Shapiro, RR Holburn, RA Carabasi: Hypofibrinogenemia associated with hemangioma of the liver. *Am J Clin Pathol* 60:192-197, 1973.
  140. Matthews CME: The theory of tracer experiments with  $^{131}\text{I}$ -labelled plasma proteins. *Phys Med Biol* 2:36-53, 1957.
  141. McFarlane AS: Efficient trace-labelling of proteins with iodine. *Nature (London)* 183:53, 1958.
  142. McFarlane AS: In vivo behavior of  $^{131}\text{I}$ -fibrinogen. *J Clin Invest* 43:346-361, 1963.
  143. McFarlane AS: Labelling of plasma proteins with radioactive iodine. *Biochem J* 62:135-143, 1956.
  144. McFarlane AS: Measurement of synthesis rates of liver-produced plasma proteins. *Biochem J* 89:277-290, 1963.
  145. McFarlane AS: Short-term measurement of catabolic rates using iodine-labeled plasma proteins. *J Clin Invest* 49:1903-1911, 1970.
  146. McFarlane AS, L Irons, A Koj, E Regoeczi: The measurement of synthesis rates of albumin and fibrinogen in rabbits. *Biochem J* 95:536-540, 1965.
  147. McFarlane RG: The reactions of the blood to injury: I. The reactions of the plasma. *In: Lord Florey (Ed): General Pathology.* Saunders, Philadelphia, 1970, Chapter 7, pp 226-243.
  148. McKay DG: Participation of components of the blood coagulation system in the inflammatory response. *Am J Pathol* 67:181-203, 1972.
  149. McKay DG: Intravascular coagulation - acute and chronic - disseminated and local. *In: G Schmer, P Strendjerd (Eds): Coagulation, Current Research and Clinical Applications.* Academic Press, New York, 1973, pp 45-72.
  150. McKinley JE, DB Gilbert, P-Y Chao, EB Reeve: Urea metabolism and distribution in rabbits treated with neomycin. *Am J Physiol* 213:491-497, 1970.
  151. McNicol G, M Browne, C Bayley, A Douglas: Pathological fibrinolytic states and their treatment with epsilon amino caproic acid. *Br J Surg* 53:26-29, 1966.
  152. McNicol GP, JA Davies: Fibrinolytic enzyme system. *Clin Haematol* 2:23-51, 1973.
  153. Merrill EW: Rheology of Blood. *Physiol Rev* 49:863-888, 1969.
  154. Michaels L: The incidence and course of cancer in patients receiving anticoagulant therapy. Retrospective and prospective studies. *J Med* 5:98-106, 1974.
  155. Millar RC, AS Ketcham: The effect of heparin and warfarin on primary and metastatic tumors. *J Med* 5:23-31, 1974.
  156. Miller H, WF Bale: Synthesis of all plasma protein fractions except gamma globulins by the liver. *J Exp Med* 99:125-132, 1959.

157. Miller LL, CG Bly, ML Watson, WF Bale: The dominant role of the liver in plasma protein synthesis. A direct study of the isolated perfused rat liver with the aid of lysine- $\epsilon$ -C<sup>14</sup>. *J Exp Med* 94:431-453, 1951.
158. Miller LL, EE Griffin: Effects on net protein synthesis of removal of  $\epsilon$ -tryptophan or  $\epsilon$ -threonine from a complete amino acid mixture: Studies in the isolated perfused rat liver. *Am J Clin Nutr* 24:718-729, 1971.
159. Miller LL, EE Griffin: *In*: I. Bartosek, A Guanitani, LL Müller (Eds): *Isolated Liver Perfusion and its Application*. Raven Press, New York, 1973, pp 11-52.
160. Miller LL, EE Griffin: Regulation of net biosynthesis of albumin, fibrinogen,  $\alpha_1$ -acid glycoprotein,  $\alpha_2$ -(acute phase) globulin and haptoglobin by direct action of hormones on the isolated perfused liver. *In*: G Litwack (Ed): *Biochemical Actions of Hormones*, Vol. 3. Academic Press (to be published).
161. Miller LL, DW John: Factors affecting net fibrinogen biosynthesis by the isolated perfused rat liver. *Thromb Diath Haemorr, Suppl* 39:127-141, 1970.
162. Monasterio G, MF Becchini, N Riccioni: Detection of tumours in man by means of <sup>1131</sup>I-fibrinogen. *Excerpta Med Int Cong Ser No.* 105:1270-1277, 1965.
163. Monasterio G, MF Becchini, N Riccioni: Radioiodinated (<sup>1131</sup>I and <sup>1125</sup>I) fibrinogen for the detection of malignant tumors in man. *Med Radio-isotope Scanning* 2:159-172, 1964.
164. Moncada S, SH Ferrera, JR Vane: Prostaglandins, aspirin-like drugs and the oedema of inflammation. *Nature (London)* 246:217-219, 1973.
165. Monkhouse FC: Preparation and assay of plasma antithrombin. *In*: GE Perlmann, L Lorand (Eds): *Methods in Enzymology, XIX, Proteolytic Enzymes*. Academic Press, New York, 1970, pp 915-924.
166. Morgan EH, T Peters: The biosynthesis of rat serum albumin. V. Effect of protein depletion and refeeding on albumin and transferrin synthesis. *J Biol Chem* 246:3500-3507, 1971.
167. Mossesson MW: Fibrinogen catabolic pathways. Determination from analyses of the structural features of circulating fibrinogen and of derivatives produced *in vitro* by the action of plasmin or thrombin. *Semin Thromb Hemost* 1:63-84, 1974.
168. Munro HN: A general survey of mechanisms regulating protein metabolism in mammals. *In*: HN Munro (Ed): *Mammalian Protein Metabolism, Vol. IV*, Academic Press, New York, 1970, pp 3-130.
169. Murano G: The molecular structure of fibrinogen. *Semin Thromb Hemost* 1:1-31, 1974.
170. Nadelhaft I, F Lamy: Fibrinogen turnover in rats as a function of age. *J Lab Clin Med* 79:724-730, 1972.
171. Naish P, DJ Evans, DK Peters: Urinary fibrinogen derivative excretion and intraglomerular fibrin deposition in glomerulonephritis. *Br Med J* 1:544-546, 1974.
172. Nanson EM, PD Palko, AA Dick, SO Fedoruk: Early detection of deep venous thrombosis of the legs using <sup>131</sup>I-tagged human fibrinogen. *Ann Surg* 162:438-444, 1965.
173. Negus D, DJ Pinto, LP LeQuesne, N Brown, M Chapman: <sup>125</sup>I-labelled fibrinogen in the diagnosis of deep vein thrombosis and its correlation with phlebography. *Br J Surg* 55:835-839, 1968.
174. Niemetz J, K Fani: Thrombogenic activity of leukocytes. *Blood* 42:47-59, 1973.
175. Niewiarowski S, Z Latallo: Influence of plasmin on the first coagulation stage. *Bull Acad Pol Sci* 5:219-226, 1957.
176. Nilsson IM, L Andersson, SE Bjorkman: Epsilon aminocaproic (EACA) acid as a therapeutic agent based on 5 years clinical experience. *Acta Med Scand Suppl* 448:5-46 1966.
177. Nordström, E Zetterqvist: Effects of thrombin infusion upon <sup>131</sup>I-labelled fibrinogen in dogs. *Acta Physiol Scand* 72:85-99, 1968.
178. Nordström S, E Zetterqvist: Effects of epsilon aminocaproic acid (EACA) and trasylol on thromboplastin-induced intravascular coagulation, studied in dogs with iodine-labelled fibrinogen. *Acta Physiol Scand* 76:93-105, 1969.
179. Norman PS, BM Hill: Studies of the plasmin system. III. Physical properties of the two plasmin inhibitors in plasma. *J Exp Med* 108:639-649, 1958.
180. Nossel HL, I Yudelman, RF Canfield, VP Butler, K Spanondis, GD Wilner, GD Quereschi: Measurement of fibrinopeptide A in human blood. *J Clin Invest* 54:43-53, 1974.

181. Ogston D, GM McAndrew: Fibrinolysis in obesity. *Lancet* 2:1205-1207, 1964.
182. Ogura T, F Hirao, E Tsubura, Y Yamamura: Autoradiographic study on localization of fibrinogen in rabbit lung cancer. *Gann* 62:367-372, 1971.
183. Ogura T, M Tatsuta, E Tsubura, Y Yamamura: Localization of fibrinogen in tumor tissue. *Gann* 58:403-413, 1967.
184. Ogura T, E Tsubura, Y Yamamura: Localization of radioiodinated fibrinogen in invaded and metastasized tumor tissue of Walker carcinosarcoma. *Gann* 61:443-449, 1970.
185. Ohlsson K, P-O Ganrot, C-B Laurell: *In vivo* interaction between trypsin and some plasma proteins in relation to tolerance to intravenous infusion of trypsin in the dog. *Acta Chir Scand* 137:113-121, 1971.
186. O'Meara RAQ, RD Jackson: Cytological observations on carcinoma. *Irish J Med Sci* 391:327-328, 1958.
187. O'Meara RAQ, RD Thornes: Some properties of the cancer coagulative factor. *Irish J Med Sci* 423:106-112, 1961.
188. Owen JA: Effect of injury on plasma proteins. *Advances Clin Chem* 9:1-41, 1967.
189. Palko PD, EM Nanson, SO Fedoruk: The early detection of deep venous thrombosis using <sup>131</sup>I-tagged human fibrinogen. *Can J Surg* 7:215-226, 1964.
190. Palos LA, G Sas, A Csurgay: Reaction kinetics of thrombin in decalcified blood and plasma. *Thromb Diath Haemorrh* 21:580-593, 1969.
191. Pearson JD, N Veall, H Vetter: A practical method for plasma turnover studies. *Radioisotope in Klinik und Praxis* 3:290-297, 1958.
192. Pennisi F, U Rosa: Preparation of radioiodinated insulin by constant current electrolysis. *J Nucl Biol Med* 13:64-70, 1969.
193. Peters JP, DD Van Slyke: *Quantitative Clinical Chemistry*, Vol. 2: Methods. Williams and Wilkins, Baltimore, 1931-2.
194. Peters T: The biosynthesis of rat serum albumin. I. Properties of rat albumin and its occurrence in liver cell fractions. *J Biol Chem* 237:1181-1185, 1962.
195. Peters T: The biosynthesis of rat serum albumin. II. Intracellular phenomena in the secretion of newly formed albumin. *J Biol Chem* 237:1186-1189, 1962.
196. Peters T, B Fleischer, S Fleischer: The biosynthesis of rat serum albumin. IV. Apparent passage of albumin through the Golgi apparatus during secretion. *J Biol Chem* 246:240-244, 1971.
197. Piessens R, D Collen, G Tytgat: Computer analysis of fibrinogen tracer data. *Comput Biomed Res* 4:585-593, 1971.
198. Pindyck J, MW Mossesson, RD Levere: Fibrinogen synthesis by cultured avian hepatocytes: Effect of various steroids. *J Clin Invest* 51:75a, 1972.
199. Pitney WR: Disseminated intravascular coagulation. *Semin Hematol* 8:65-83, 1971.
200. Rake MO, PT Flute, G Pannell, KB Shilkin, R Williams: Experimental hepatic necrosis: Studies on coagulation abnormalities, plasma clearance and organ distribution of <sup>125</sup>I-labeled fibrinogen. *Gut* 14:574-580, 1973.
201. Ratnoff OD, C Menzie: New method for the determination of fibrinogen in small samples of plasma. *J Lab Clin Med* 37:316-320, 1951.
202. Rausen AR, A Cruchaud, CW McMillan, D Gitlin: A study of fibrinogen turnover in classical hemophilia and congenital afibrinogenemia. *Blood* 18:710-716, 1961.
203. Reeve EB: The measurement of the synthetic rate of liver-synthesized proteins in animals. *In: Vienna: Int Atomic Energy Agency: Radio-isotope Techniques in the Study of Protein Metabolism*, Tech Rept Ser No. 45, 1965, pp 57-69.
204. Reeve EB, HR Bailey: Mathematical models describing the distribution of <sup>113</sup>I-albumin in man. *J Lab Clin Med* 60:923-943, 1962.
205. Reeve EB, AY Chen: Regulation of interstitial albumin. *In: MA Rothschild, T Waldmann (Eds): Plasma Protein Metabolism*. Academic Press, New York, 1970, pp 89-109.
206. Reeve EB, W Lew, T Carlson: The <sup>14</sup>C-bicarbonate method of measuring plasma protein synthetic rate and its simplification. *Proc Turin Conf on Plasma Protein Metabolism*, 1974.
207. Reeve EB, JE McKinley: Measurement of albumin synthetic rate with bicarbonate-<sup>14</sup>C. *Amer J Physiol* 218:498-509, 1970.
208. Reeve EB, JR Pearson, DC Martz: Plasma protein synthesis in the liver: Method for

- measurement of albumin formation *in vivo*. *Science* 139:914-916, 1963.
209. Reeve EB, JE Roberts: The kinetics of the distribution and breakdown of  $^{113}\text{I}$ -albumin in the rabbit. *J Gen Physiol* 2:415-444, 1959.
  210. Reeve EB, Y Takeda, AC Atencio: Some observations on the mammalian fibrinogen system in non-steady and steady states. *Protides Biol Fluids Proc Colloq* 14:283-294, 1966.
  211. Regoeczi E: Effects of clotting on the label in iodinated fibrinogen in different species. *Thromb Diath Haemorrh* 17:237-246, 1967.
  212. Regoeczi E: Fibrinogen catabolism: Kinetics of catabolism following sudden elevation of the pool with exogenous fibrinogen. *Clin Sci* 38:111-121, 1970.
  213. Regoeczi E: Iodine-labelled fibrinogen: A review. *Br J Haematol* 20:649-663, 1971.
  214. Regoeczi E, L Irons, A Koj, AS McFarlane: Isotopic studies of urea metabolism in rabbits. *Biochem J* 95:521-535, 1965.
  215. Regoeczi E, GE Regoeczi, AS McFarlane: Relation between rate of catabolism, plasma concentration and pool size of fibrinogen. *Pflüger Arch* 279:17-25, 1964.
  216. Regoeczi E, PL Walton: Effects of clotting on the label in iodinated fibrinogen in different species. *Thromb Diath Haemorrh* 17:237-246, 1967.
  217. Regoeczi E, PL Walton: Metabolism of  $^{125}\text{I}$ -fibrinogen in normal monkeys and in those with pharmacologically induced plasminogen activator release. *Clin Sci* 33:449-468, 1967.
  218. Regoeczi E, K-I. Wong: Effects of intravenous neuraminidase on the turnover of fibrinogen. *In: GEW Wolstenholme, M O'Connor (Eds): Protein Turnover. Ciba Foundation Symposium 9 (New Series). Elsevier, New York, 1973, pp 181-197.*
  219. Riccioni N: Diagnosis of malignant lesions of the liver by radiocolloid and  $^{131}\text{I}$ -fibrinogen. *J Biol Nuc Med* 13:160-166, 1969.
  220. Riccioni N, MF Becchini, M Aloisi: Differentiation of malignant neoplasms from other lesions using radioactive fibrinogen. *Minerva Nucleare* 9:451-457, 1965.
  221. Riccioni N, MF Becchini, F Vitek, L Donato: Analog computer study of the kinetics of extravascular distribution of  $^{131}\text{I}$ -labelled plasma proteins in normal and tumoral tissues. *Proc conf on problems connected with the preparation and use of labelled proteins in tracer studies 1966*, pp 193-198.
  222. Riccioni N, G De Renzi, MF Becchini, A Bartorelli: The time course of radiofibrinogen uptake in the I.R.E. sarcoma and in acute inflammatory process as induced in rats. *Minerva Nucleare* 9:250-252, 1965.
  223. Riggs DS: Control theory and physiological feedback mechanisms. *Williams and Wilkins, Baltimore, 1970, 599p.*
  224. Ro JS, A Flatmark: Studies on thrombin infusion in dogs. *Scand J Haematol* 9:293-304, 1972.
  225. Robbins KC, L Summaria: Human Plasminogen and Plasmin. *In: GE Perlmann, L Lorand (Eds): Methods in Enzymology. XIX, Proteolytic Enzymes. Academic Press, New York, 1970, pp 184-199.*
  226. Robertson BR: On thrombosis, thrombolysis and fibrinolysis. *Acta Chir Scand Suppl* 421:5-51, 1971.
  227. Rosenberg RD, PS Damus: The purification and mechanism of action of human antithrombin-heparin cofactor. *J Biol Chem* 248:6490-6505, 1973.
  228. Rosenoer VM, MA Rothschild: The extravascular transport of albumin. *In: MA Rothschild, T Waldmann (Eds): Plasma Protein Metabolism. Academic Press, New York, 1970, Chapter 7, pp 111-127.*
  229. Rosing DR, P Brakeman, RE Goldstein, GD Beiser, T Astrup, SE Epstein: Blood fibrinolytic activity in man: Diurnal variation and the response to varying intensities of exercise. *Circ Res* 27:171-184, 1970.
  230. Rossing N, O Bärenholdt: Whole body counting in metabolic studies of  $^{131}\text{I}$ -labelled albumin. *Scand J Clin Lab Inv* 19:331-338, 1967.
  231. Rossing N, H-H Parving, NA Lassen: Albumin transcapillary escape rate as an approach to microvascular physiology in health and disease. *Sixth Int Symp on Plasma Protein Turnover, Torino, Italy, May 22-25, 1974. To be published.*
  232. Rothschild MA, M Oratz, SS Schreiber: Albumin synthesis. *New Eng J Med* 286:748-757, 816-821, 1972.

233. Rothschild MA, M Oratz, D Zimmon, SS Schreiber, I Weiner, A Van Caneghem: Albumin synthesis in cirrhotic subjects with ascites studied with carbonate-<sup>14</sup>C. *J Clin Invest* 48:344-350, 1969.
234. Rubenberg ML, LRI Baker, JA McBride, LM Sevitt, MC Brain: Intravascular coagulation in a case of *Clostridium perfringens* septicaemia: Treatment by exchange transfusion and heparin. *Br Med J* 4:271-274, 1967.
235. Rubenberg, ML, E Regoczi, BS Bull, JV Dacie, MC Brain: Microangiopathic hemolytic anemia: The experimental production of haemolysis and red cell fragmentation by defibrination *in vivo*. *Br J Haematol* 14:627-642, 1968.
236. Ruckdeschel JC, T Peters Jr, KT Lee: Fibrinogen catabolism in rats fed thrombogenic diets. *Atherosclerosis* 16:277-285, 1972.
237. Schimke RT: Control of enzyme levels in mammalian tissues. *Adv Enzymol* 37:135-187, 1973.
238. Seligsohn U, SI Rappaport, PR Kuefler: Extra-adrenal effect of ACTH on fibrinogen synthesis. *Am J Physiol* 224:1172-1179, 1973.
239. Shainoff JR, IH Page: Cofibrins and fibrin-intermediates as indicators of thrombin activity *in vivo*. *Circ Res* 8:1013-1022, 1960.
240. Shea SM, MJ Karnovsky: Vesicular transport across endothelium. Simulation of a diffusion model. *J Theor Biol* 24:30-42, 1969.
241. Shen SM, SI Rapaport: Increased fibrinogen consumption following endotoxin injection in cortisone-treated rabbits. *Proc Soc Exp Biol Med* 145:851-854, 1974.
242. Sherman LA: Fibrinogen turnover: Demonstration of multiple pathways of catabolism. *J Lab Clin Med* 79:710-723, 1972.
243. Sherman LA, AP Fletcher, S Sherry: *In vivo* transformation between fibrinogen of varying ethanol solubilities: A pathway of fibrinogen catabolism. *J Lab Clin Med* 73:574-583, 1969.
244. Simmons AV, MA Sheppard, AF Cox: Plasma <sup>125</sup>I-labelled fibrinogen clearance in diagnosis of deep vein thrombosis after myocardial infarction. *Br Heart J* 34:711-716, 1972.
245. Simpson JG, AL Stalker: The concept of disseminated intravascular coagulation. *Clin Haematol* 2:189-198, 1973.
246. Soria J, C Soria, E Vairel, RJ Prost, G Warneson: Experimental study of fibrinogen degradation products. Influence of plasminogen level for the interpretation of serum concentration of fibrinogen degradation products in consumption coagulopathies. *Thromb Diath Haemorrh* 29:115-121, 1973.
247. Spar IL, WF Bale, D Marrack, WC Dewey, RJ McCardle, PV Harper: <sup>131</sup>I-labeled antibodies to human fibrinogen: Diagnostic studies and therapeutic trials. *Cancer* 20:865-870, 1967.
248. Spiegel MR: *Theory and Problems of Laplace Transforms*. Schaum Publishing Co, New York, 1965.
249. Straub PW: Behavior of I-<sup>125</sup> labeled fibrinogen during therapeutic defibrination with highly purified reptilase (defibrase). *Schweiz Med Wochenschr* 101:1802-1804, 1971.
250. Straub PW: Chronic intravascular coagulation. Clinical spectrum and diagnostic criteria, with special emphasis on metabolism, distribution and localization of I <sup>131</sup>I-fibrinogen. *Acta Med Scand Supp* 526:1-95, 1971.
251. Straub PW, S Kessler, A Schreiber, PG Frick: Chronic intravascular coagulation in Kasabach-Merritt syndrome. Preferential accumulation of fibrinogen-<sup>131</sup>I in a giant hemangioma. *Arch Int Med* 129:475-478, 1972.
252. Takeda Y: Effects of endotoxin on fibrinogen and prothrombin metabolism in calves. *In*: MA Rothschild, TA Waldmann (Eds): *Plasma Protein Metabolism*. Academic Press, New York, 1970. pp 443-458.
253. Takeda Y: Plasminogen-<sup>125</sup>I response in dogs to a single injection of urokinase and typhoid vaccine and to vascular injury. *J Clin Invest* 51:1363-1377, 1972.
254. Takeda Y: Studies of the metabolism and distribution of fibrinogen in patients with rheumatoid arthritis. *J Lab Clin Med* 69:624-633, 1967.
255. Takeda Y: Studies of the metabolism and distribution of fibrinogen in healthy men with autologous <sup>125</sup>I-labelled fibrinogen. *J Clin Invest* 45:103-111, 1966.

256. Takeda Y: Fibrinogen metabolism in patients with essential hypertension. *Fed Proc* 25:45, 1966. Abstract.
257. Takeda Y, AY Chen: Fibrinogen metabolism and distribution in patients with the nephrotic syndrome. *J Lab Clin Med* 70:678-685, 1967.
258. Takeda Y, A Chen: Studies of the metabolism and distribution of fibrinogen in patients with hemophilia A. *J Clin Invest* 46:1979-1984, 1967.
259. Takeda Y, M Nakabayashi: Physicochemical and biological properties of human and canine plasmins. *J Clin Invest* 53:154-162, 1974.
260. Takeda Y, EB Reeve: The distribution and excretion of  $^{131}$ I-iodide in man on pharmacological doses of iodides. *J Lab Clin Med* 60:944-953, 1962.
261. Tavill AS, AG East, EG Black, D Nadkarni, R Hoffenburg: Regulatory factors in the synthesis of plasma proteins by the isolated perfused liver. *In: GE Wolstenholme, M O'Connor (Eds): Protein Turnover. Ciba Foundation Symposium 9 (New Series), Elsevier, New York, 1973, pp 155-171.*
262. Tavill AS, A Craigie, VM Rosenoer: The measurement of the synthetic rate of human albumin in man. *Clin Sci* 34:1-28, 1968.
263. Teulings FA, GJ Biggs: Study of electrolytic labeling of fibrinogen with  $^{131}$ I-iodine by Sephadex G-10 gel filtration. *Clin Chim Acta* 27:57-64, 1970.
264. Thorne RD: Oral anticoagulant therapy of human cancer. *J Med* 5:83-91, 1974.
265. Thorne RD, H Smyth, O Browne, M O'Gorman, DJ Reen, D Farrell, PDJ Holland: The effects of proteolysis on the human immune mechanism in cancer. A preliminary communication. *J Med* 5:92-97, 1974.
266. Tytgat GN, D Collen, SL Oei, B VanDamme: Fibrinogen metabolism in healthy dogs and in dogs with  $\text{CCl}_4$ -induced liver damage and with portal vein occlusion. *Thromb Diath Haemorrh* 27:319-336, 1972.
267. Tytgat GN, D Collen, J Vermeylen: Metabolism and distribution of fibrinogen. II. Fibrinogen turnover in polycythaemia, thrombocytosis, haemophilia A, congenital afibrinogenaemia and during streptokinase therapy. *Br J Haematol* 22:701-717, 1972.
268. Tytgat GN, D Collen, M Verstraete: Metabolism of fibrinogen in cirrhosis of the liver. *J Clin Invest* 50:169-701, 1971.
269. Van der Maas APC, FAG Teulings, GHJ den Ottolander: The use of a labelled fibrinogen in the diagnosis of venous thrombosis. *Thromb Diath Haemorrh* 26:1-8, 1971.
270. von Hugo R, H Graeff: Formation of soluble fibrin monomer complexes in human plasma. *Thromb Res* 3:183-190, 1973.
271. Wainwright SD: *Control Mechanisms and Protein Synthesis*. Columbia University Press, New York, 1972.
272. Walker ARP: Fibrinolytic activity of whole blood from South African Bantu and white subjects. *Amer J Clin Nutr* 9:461-472, 1961.
273. Walsh KA: Trypsinogens and trypsins of various species. *In: GE Perlmann, L Lorand (Eds): Methods in Enzymology, XIX, Proteolytic Enzymes. Academic Press, New York, 1970, pp 41-63.*
274. Wardle EN: Fibrinogen catabolism studies in patients with renal disease. *Q J Med* 42:205-219, 1973.
275. Wardle EN: Intravascular coagulation in infection: A study by radio-fibrinogen. *Scand J Infect Dis* 4:155-159, 1972.
276. Wardle FN, M Floyd: Fibrinogen catabolism study of 3 patients with bacterial endocarditis and renal disease. *Br Med J* 3:255-257, 1973.
277. Warlow CP, D Ogston: The  $^{125}$ I-fibrinogen technique in the diagnosis of venous thrombosis. *Clin Haematol* 2:199-212, 1973.
278. Weiss P: The biological foundations of wound repair. *Harvey Lect* 55:13-42, 1961.
279. Werb Z, MC Burtleigh, AJ Barrett, PM Starkey: The interaction of  $\alpha_2$ -macroglobulin with proteinases. *Biochem J* 139:359-368, 1974.
280. Williams TJ, J Morley: Prostaglandins as potentiators of increased vascular permeability in inflammation. *Nature (London)* 246:215-217, 1973.
281. Wintrobe MM: *Clinical Hematology*, 6th Ed. The blood as a whole. Lea and Febiger, Philadelphia, 1967, Chapter 6.
282. Wochner RD, SM Weissman, TA Waldmann, D Houston, NI Berlin: Direct measurement of the rates of synthesis of plasma proteins in control subjects and patients with gastrointestinal protein loss. *J Clin Invest* 47:971-992, 1968.

283. Wolf PL: Disseminated intravascular coagulation: Principles of diagnosis and management. *In*: G Schmer and PE Strandjord (Eds): Coagulation. Current Research and Clinical Applications. Academic Press, New York, 1973, pp 17-44.
284. Wolstenholme GEW, M O'Connor: Protein Turnover. Ciba Foundation Symposium 9 (New Series). Elsevier, New York, 1973. General Discussion, pp 297-308.
285. Wood S: Experimental studies on the spread of cancer, with special reference to fibrinolytic agents and anticoagulants. *J Med* 5:7-22, 1974.
286. Wycoff AD: Production of fibrinogen following an endotoxin injection. *Proc Soc Exp Biol Med* 133:940-947, 1970.
287. Zetterqvist E: Elimination of iodine-labelled fibrinogen in intravascular coagulation and in the normal state. Experimental and clinical studies. *Acta Physiol Scand Suppl* 325:1-41, 1969.
288. Zizza F, TJ Campbell, EB Reeve: The nature and rates of excretion of radioactive breakdown products of  $^{131}\text{I}$ -albumin in the rabbit. *J Gen Physiol* 43:397-413, 1959.